

ValidatorPRO and ValidatorPRO-NT

User's Guide

www.jdsu.com/know



Table of Contents

1	Introduction	1
1.1	ValidatorPRO Capability	3
1.2	ValidatorPRO-NT	3
2	About Your ValidatorPRO	5
2.1	Main Unit Features	5
2.2	Remote Unit Features.....	8
2.3	ValidatorPRO kit contents (ValidatorPRO NT1150 and ValidatorPRO-NT NT1155).....	10
3	Battery and Power Management	11
4	Integration with Plan-Um Software	13
4.1	Summary of Auto Test Steps	14
5	Basic Operation	15
6	Setup Menu	17
6.1	Display Contrast	18
6.2	Shutdown Timeouts	19
6.3	Date/Time	20
6.4	Localization.....	21
6.5	Calibration (Test Lead Compensation)	22
6.6	Other Settings.....	22
7	Properties Menu	25
7.1	Battery Info	26
7.2	Product Version	27
7.3	Memory Usage	28
7.4	Support Info	29
8	File Management Menu	31
8.1	Job Manager.....	32
8.2	Copy/Move Utility.....	33
9	Auto Test Menu	35
9.1	Cable Test Schedule	36
9.1.1	Viewing Test Results	38
9.2	Site Information	39
9.3	Tester Information.....	40
9.4	Custom Cable Definitions	41

Table of Contents

- 9.5 Job Utilities42
 - 9.5.1 New Job42
 - 9.5.2 Open Job42
 - 9.5.3 Export TuT43
 - 9.5.4 Save43
 - 9.5.5 Save As43
- 10 Manual Test Menu.....45
 - 10.1 Data Cables46
 - 10.1.1 Cable Test47
 - 10.2 Phone Cables48
 - 10.3 Two-Wire Cables48
 - 10.4 Fiber Cables49
- 11 Network Test Menu (ValidatorPRO-NT)51
 - 11.1 Power over Ethernet (PoE)52
 - 11.2 Port Discovery53
 - 11.3 Ping55
 - 11.4 Layer 2 Discovery Protocols58
 - 11.5 Hub Flash59
 - 11.6 Wireless Networks59
- 12 WEEE Directive Compliance61
- 13 Customer Services and Warranty63
 - 13.1 Customer Service (Standard Services).....63
 - 13.2 Technical Assistance63
 - 13.3 Repair, Calibration and Upgrades.....63
 - 13.3.1 Repair63
 - 13.3.2 Calibration64
 - 13.3.3 Factory Upgrades64
 - 13.3.4 Equipment Return Instructions64
 - 13.4 Warranty Information65
 - 13.4.1 Warranty registration65

1 Introduction

The ValidatorPRO series of Ethernet Network Management Tools offers a complete solution to test copper and fiber Ethernet cables. The ValidatorPRO performs speed certification to test the data-carrying capabilities of electrical Ethernet network cables up to 1 Gb/s by testing for noise in the network, detecting faults in the cabling wiring, and ensuring that cables are able to support the speed capabilities of active equipment.

To certify Ethernet speed performance of copper cable runs, the ValidatorPRO series of handheld testers conducts Bit Error Rate (BER) tests by sending data packets down specified cable runs at defined data rates to check for errors at the maximum throughput of the link. The ValidatorPRO also reports on signal quality that can impact high-speed data transmission by measuring signal-to-noise ratio (SNR). Skew measurements report on the signal time delay between pairs that can impact Ethernet data transmission. The ValidatorPRO also provides continuity testing that detects opens, shorts, miswires, split pairs, reversals, and high-resistance faults while accurately measuring distance to faults and total cable length.

The ValidatorPRO includes an integrated optical power meter that measures optical power at 850/1300/1310/1490/1550 nm on multimode or single-mode fiber to address an increasing number of Ethernet networks that now include optical links.

The ValidatorPRO-NT version includes a comprehensive set of features for testing a network's active network capabilities: measure Power over Ethernet (PoE) to ensure the correct power is available on the correct pins, use port discovery to ensure the correct speed and duplex capability are available; connect at gigabit Ethernet and run ping tests to verify connectivity to IP hosts; discover network devices using Cisco Discovery Protocol (CDP) or Link Layer Discovery Protocol (LLDP), discovery and display essential information

Introduction

regarding functionality and configuration of 802.11 b/g/n networks.

The ValidatorPRO solution includes the powerful Plan-Um® planning and reporting software for planning network architectures and organizing cable information and test results. Plan-Um helps set up each job, defines scope of the job, aids in testing cable runs, and produces reports for the installer and customer. The Network Tools feature provides a quick way to see the network architecture and a way to document moves, adds, and changes.

1.1 ValidatorPRO Capability

- Measures optical power on SM and MM fiber
- Conducts Bit Error Rate (BER) testing to speed certify Ethernet data transmission speed up to 1000BASE-T (1 Gb/s)
- Measures Signal-to-Noise Ratio and Skew to uncover impairments to electrical Ethernet data transmission
- Tests for opens, shorts, split pairs, miswires, and reversals and measures distance to opens and shorts—supports all copper network, telco, and coax cables
- Supports sets of 20 ID-only remote identifiers: TP311 (coax), TP312 (RJ45), TP314 (RJ11) and KP420 (master kit)
- Identifies cable termination on active Ethernet ports with hub flash
- Includes Plan-Um® software to create network layout, document cable tests, show network topology, and record moves, adds, and changes

1.2 ValidatorPRO-NT

The –NT version (NT1155) adds the following:

- Measures Power over Ethernet (PoE) voltage and current
- Performs port discovery to detect advertised Ethernet speed and displays capabilities of network devices
- Pings network devices to verify connectivity to active equipment
- Discovers and displays essential information regarding functionality of 802.11 b/g/n wireless devices
- Used in conjunction with Plan-Um, ValidatorPRO provides confidence in the physical properties of cable runs and the overall capability of the network.

2 About Your ValidatorPRO

2.1 Main Unit Features

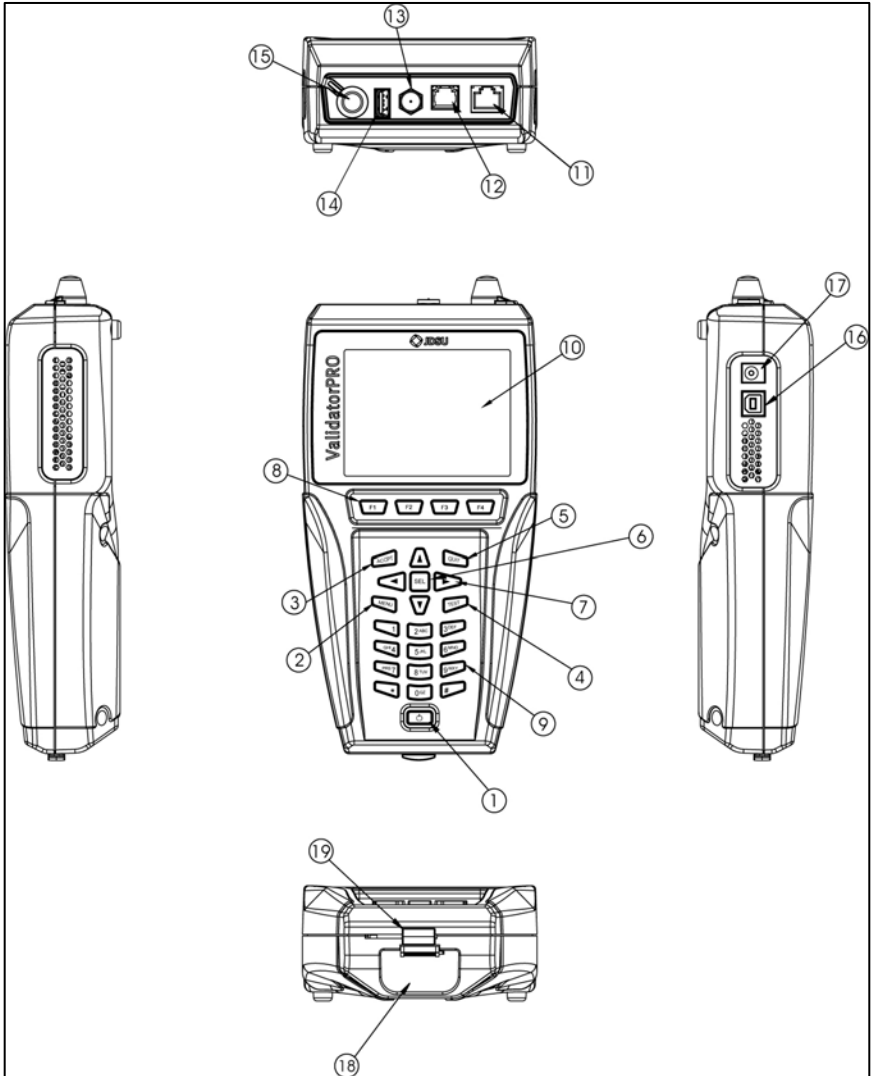





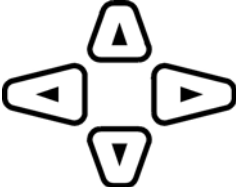



Figure 2.1: Main Unit Features

About Your ValidatorPRO

Table 1: Main Unit Features

Item	Feature	Description
1		Power Key is pushed to power unit on/off. When unit is on a short tap changes the backlight from dim to bright. Holding key down for over a second turns the unit off.
2		Menu Key opens a shortcut window of simple functions
3		Accept Key accepts the current selection or edited field.
4		Test Key runs the automatic test sequence for the highlighted cable.
5		Quit Key exits the current selections or moves backup in the menu sequence.
6		Select Key enables editing of currently highlighted field or activates the next level into the menu navigation sequence.
7		Arrow Keys are used for navigation of the active-selected field on the current menu.
8		Context Sensitive function keys enable the soft keys, which appear on the bottom of the LCD screen.
9		Alphanumeric keypad used to enter data. Pressing the 1 key multiple times displays the following special characters: @ () - . , and space. The (*) key is also a shortcut for the (.) period punctuation mark.

About Your ValidatorPRO

Table 2: Main Unit Features (Cont.)

Item	Feature	Description
10	Display	4 inch LCD color screen
11	Data Jack	RJ45 8 Position 8 Conductor (8P8C) modular connector. T568A/B Wiring
12	Telephone Jack	RJ11 6 Position 6 Conductor (6P6C) modular connector. USOC Wiring
13	Coaxial Cable Connector	Male "F" Connector. Coaxial Cable Interface
14	USB Host Port	USB 2.0 host connector for external flash memory
15	Universal Push Pull Fiber Adapter	2.5 mm or 1.25 mm (user interchangeable) universal push pull adaptor for optical power meter
16	USB Client Port	For future use
17	DC Power Connector	For connection to external power supply
18	Battery	Li-ion rechargeable battery (NT93)
19	Battery Lock	Sliding lever to secure battery

2.2 Remote Unit Features

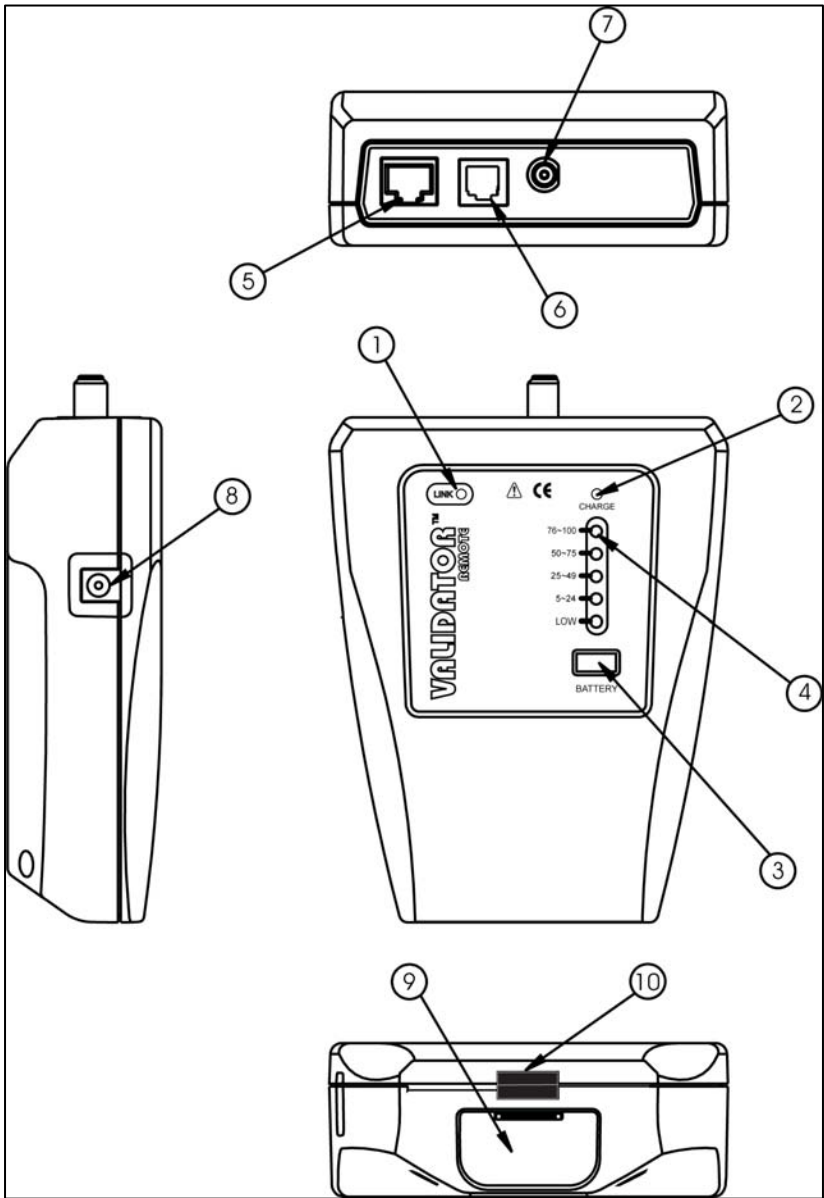

Figure 2.2: Remote Unit Features

About Your ValidatorPRO

Table 3: Remote Unit Features

Item	Feature	Description
1	Link LED	Turns on when a link is established with another network device (typically the ValidatorPRO main unit).
2	Charge LED	Battery is charging when LED light is blinking.
3	Battery State	When selected the battery capacity is shown.
4	Battery State Indicator	Shows percentage of battery charge remaining. A LOW indication indicates the battery must be recharged immediately.
5	Data Jack	RJ45 8 Position 8 Conductor (8P8C) modular connector. T568A/B Wiring
6	Telephone Jack	RJ11 6 Position 6 Conductor (6P6C) modular connector. USOC Wiring
7	Coaxial Cable Connector	Male "F" Connector. Coaxial Cable Interface
8	DC Power Connector	For connection to external power supply

2.3 ValidatorPRO kit contents (ValidatorPRO NT1150 and ValidatorPRO-NT NT1155)

- One smart remote
- One set 1-8 wiremapping remotes (RJ11/RJ45) (TP612)
- Two lithium ion rechargeable batteries (NT93)
- Two universal AC adapter/charger units
- One 1.83 m (72 in) USB client-to-PC connection cable (series A plug to series B plug)
- Two 19 cm (7.5 in) RJ12 to RJ12 cables for no-fault connection to RJ11 or RJ45 jacks
- Two 30.48 cm (1 ft) patch cables with RJ45 connectors
- Two 60.96 cm (2 ft) RJ45 to 8 alligator clips cord sets
- Two sacrificial cables for RJ45 mod plug
- One sacrificial coupler F-jack to F-jack
- USB drive including Plan-Um® cabling installation and planning software, user guide (product manual), and ValidatorPRO firmware
- Deluxe carrying case
- 100 “speed certified” cable labels
- One 12V vehicle charger

3 Battery and Power Management

The ValidatorPRO requires two (7.2V Li-ion) batteries – one main unit, one remote. Use only JDSU batteries, (included).

NOTE: Each battery must be fully charged (\approx 8 hours) the first time it is used to report correct remaining charge capacity immediately after a full charge. If the battery is replaced, it is necessary to start a new charge cycle by either disconnecting the AC adapter momentarily or pressing the Reset Charge (RST CHR) soft key (F1) on the Properties/Battery Info. The batteries in the main unit and the remote unit are interchangeable.

When powered on, the ValidatorPRO reports the charging status at the top of the screen under the battery icon. A green full battery icon indicates the battery is fully charged. As the battery discharges, the percentage of remaining charge is displayed in 10% steps. The battery icon changes from green to amber when the battery reaches approximately 30% of its charge capacity.

When the battery is low, the battery icon will change to red and begin to flash. An audible warning tone will sound when the battery reaches low to notify the user that in approximately three minutes, the ValidatorPRO will power down automatically and save the current job.

In addition to the charging status, additional information that is useful to monitor the loss of capacity in the battery over time is displayed on the Battery Properties screen.

Charging will continue when the ValidatorPRO is powered off but there is no visual indication. The ValidatorPRO has various timeout conditions to conserve battery life. The specific timeout values are adjustable in the Setup, Shutdown Timeouts screen.

The batteries continue to charge during operation. The batteries included in the kit are designed to work with the ValidatorPRO battery information system. They have the ability to store usage information that can be used to monitor

Battery and Power Management

the loss of capacity in the battery over time. Using other batteries not supplied by JDSU will result in not knowing the battery condition or state of charge.

Depending on the test being run, each unit can run on battery power for up to eight hours. Since the remote uses considerably less power than the ValidatorPRO main unit, a full day's use can be assured by swapping the batteries between the two in the middle of the day.

The lithium-ion batteries for ValidatorPRO can be used and stored in locations that do not exceed 122 degrees Fahrenheit (50 degrees Celsius) or 32 degrees Fahrenheit (0 degrees Celsius) limits. If the ValidatorPRO senses an out of range condition while charging, it displays Hot or Cold below the battery symbol and suspends charging. The remote flashes the charging light rapidly and suspends charging for as long as the temperature is out of range.

ValidatorPRO will not be able to provide accurate test results if the AC power is not grounded properly. It is recommended that both the main unit and remote are operated on battery power (not AC power) during the cable tests.

4 Integration with Plan-Um Software

The ValidatorPRO kit includes Plan-Um Cabling Project Management software that allows for the planning of jobs, automating testing, and generating reports. Plan-Um can be installed on a PC from the included USB thumb drive. Plan-Um can then be used to create job files that include some or all of these elements:

- Job information – details of the tester and the job site.
- Network view – logical view of network topology
- Floor plan – physical view of network topology
- Inventory – what material is needed for the job
- Cable test schedule – what cables need to be tested and what tests need to be run on each cable.
Standard and custom cable types can be used.

Once the job file is created in Plan-Um it can be transferred or saved to the USB thumb drive from the PC and then opened on the ValidatorPRO. The cable test schedule will be available in the auto test menu. Cables can then be tested using the auto test function. Tests performed on specific cable types will be determined by the cable definition.

Once all tests are complete, the job file can be saved to the USB thumb drive and transferred back to the PC where it can be opened, analyzed, and reports can be printed.

Reports can contain some or all of these elements:

- Job information – details of the tester and the job site.
- Network view – logical view of network topology
- Floor plan – physical view of network topology
- Inventory – what material was used in the job
- Cable test summary
- Cable test details – details of test results for each cable tested.
- Job notes

Please refer to the auto test menu section for further details.

Integration with Plan-Um Software

4.1 Summary of Auto Test Steps

- Create job on PC using Plan-Um
- Transfer Plan-Um job file to USB thumb drive
- Open job file on ValidatorPRO (can chose to transfer job file to ValidatorPRO internal memory first or to simply open direct from USB thumb drive)
- Use cable test schedule to run auto tests on cables
- Save job file to USB thumb drive
- Transfer job file to PC and open with Plan-Um
- Print reports

5 Basic Operation

This section describes the basic operation and navigation of the ValidatorPRO user interface (UI). The following sections provide details on how to perform specific functions and tests.

The main unit is turned on by pressing the red power button. Once on, this button can be momentarily pressed to toggle the backlight from dim to bright. Holding the power button down for more than one second turns the unit off.

When in a menu, the arrow keys are used to highlight a menu choice. The SElect key is then pushed to access the highlighted choice.

Once in a sub-menu, or at an option screen, the QUIT key is used to return to the previous menu. The top left section of the display identifies the current screen.

Pull-down selection menus are available in most views. For example, in the cable test schedule it is possible to change the cable type being tested. For pull-down menus the SElect key is used to select the field and activate the pull down menu. The arrow keys are then used to highlight a specific choice. Finally, the ACCPT (accept) key is pressed to accept the highlighted choice.

When entering alphanumeric text (entering job information for example), the keypad is used. The keypad functions much like that of a multi-tap configured cell phone – multiple presses of the same key toggles through the choices. For example, repeated presses of the “5” key show the following choices: 5, j, k, l, J, K, L. The ACCPT or right arrow keys can be used to move to the next character location.

The MENU key opens a shortcut window of common functions. The content of this window is context sensitive to the screen that is currently active but will always show the following five choices:

1. Home
2. Save Job

Basic Operation

3. Job Manager
4. Copy/Move Utility
5. Take Screenshot

Home provides a shortcut to the home screen (preventing repeated presses of the QUIT key)

Save Job saves the current job. This is particularly useful if the auto-save function has been turned off and a job needs to be saved partway through the cable test schedule. The currently active job file is always displayed in the top left corner of the display.

Job Manager and Copy/Move Utility provide a shortcut to these two File Management Utilities.

Take Screenshot saves the current screen to the internal memory as a .png file. Screenshots can be transferred from internal to external memory using the copy/move utility.

6 Setup Menu

The Setup menu allows the user to adjust internal functions such as Display Contrast, the internal time clock, English or Metric units, the displayed language, Shutdown Timeouts, perform Response Tests, and turn on Auto-Save. Most of these functions can be set once and left alone unless a specific change is desired.

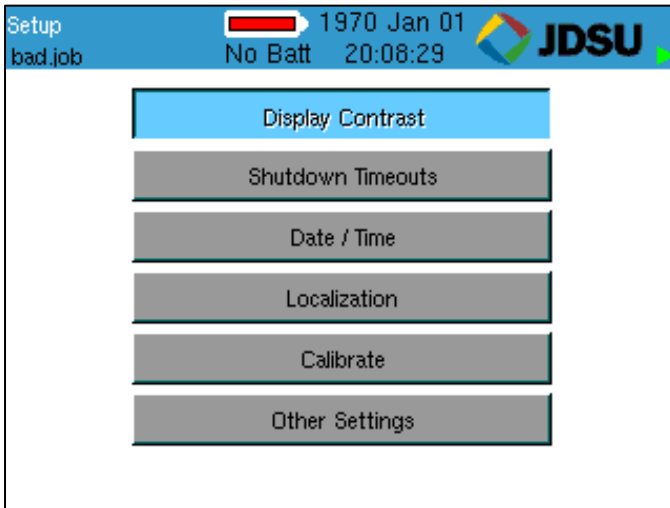

Figure 6.1 Setup Menu

Setup

6.1 Display Contrast

The ValidatorPRO main unit allows contrast settings for different environments. Use the + (F1) soft key to increase the contrast for a dark environment or – (F2) soft key to decrease the LCD contrast in a bright environment.

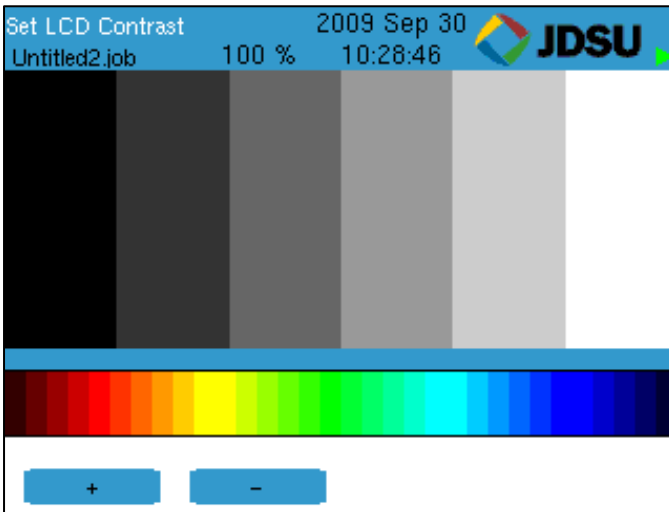

Figure 6.2 Display Contrast

6.2 Shutdown Timeouts

Several power save options are available on the ValidatorPRO to conserve battery life.

- The screen saver (Backlight) timeout will cause the display to blink. Pressing any key will bring back the full screen and reset the timer.
- The operating system timeout will cause the unit to shut down in any mode but tone generator.
- The tone generator timeout will cause the unit to shut down when in tone generation mode.

Click the down arrow on each drop-down dialog box and select the number of minutes desired before each function turns off. Press Accept, and then press Set (F1) to initiate your selections and return to the Setup screen.

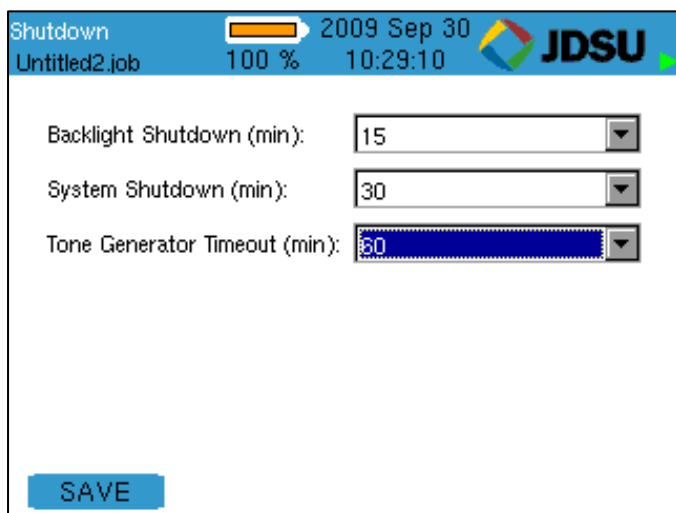
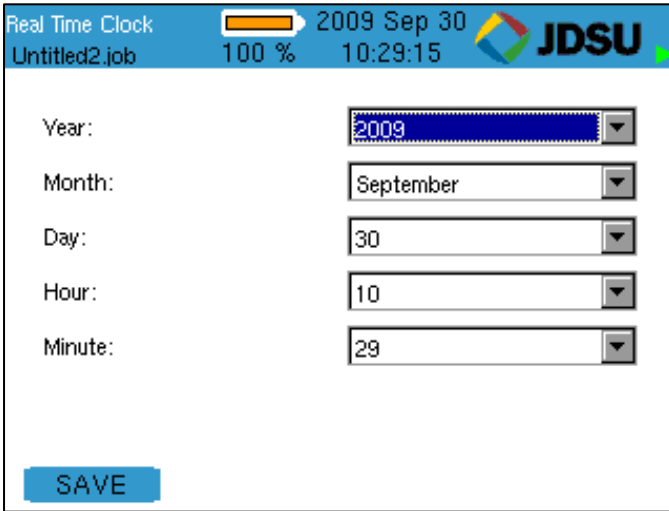

Figure 6.3 Shutdown Timers

Setup

6.3 Date/Time

Using the drop-down dialog boxes, select the current year, month, day, hour, and minute. Press Accept to select your choice and move to the next field. Press Set (F1) to confirm your choices and return to the Setup Screen.



The screenshot shows a software window titled "Real Time Clock" with a blue header bar. The header bar contains the text "Real Time Clock", a progress indicator (a yellow bar), "2009 Sep 30", and the "JDSU" logo. Below the header, the window title is "Untitled2.job", the zoom level is "100 %", and the current time is "10:29:15". The main area of the window contains five drop-down menus for date and time selection:

Year:	2009
Month:	September
Day:	30
Hour:	10
Minute:	29

At the bottom left of the window is a blue button labeled "SAVE".

Figure 6.4 Real Time Clock

6.4 Localization

Using the drop-down dialog box, select Metric or English units to report length measurements. Press Accept. Do the same for the language selection. Press OK to confirm your choice and return to the Setup screen.

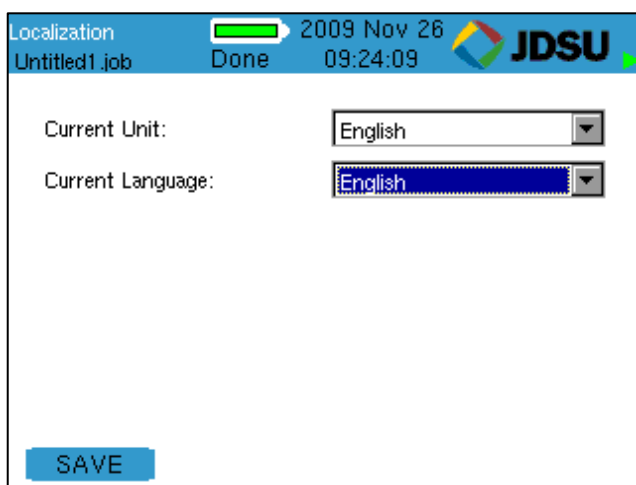

Figure 6.5: Localization

Setup

6.5 Calibration (Test Lead Compensation)

The calibration (test lead compensation) procedure is performed to set a reference point for cable length to 0 feet/meters. This can be used to compensate for the length of a test cable – the end of the test cable will be 0 feet/meters after this function is performed. Once calibration is performed, the ValidatorPRO retains the information.

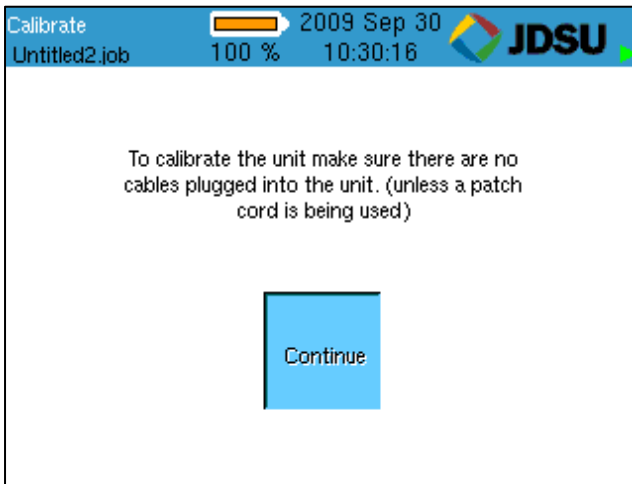

Figure 6.6 Calibration

6.6 Other Settings

The Other Settings button allows the user to be able to turn on and off the cable frequency response (attenuation) tests that are run during an auto test. In addition, the user can turn on and off the auto-save performed after each cable is tested. Using the drop-down dialog box next to the label 'Perform Response Tests', select Yes or No to turn on or off the cable frequency response test during an 'Auto Test'. Using the drop-down dialog box next to the label 'Turn On Auto- Save', select Yes or No to turn on or off the auto-save feature performed after each cable test during an 'Auto Test'. Press Accept to set the selection. Press OK to confirm your choice and return to the Main menu screen.

There are three different results that are generated and graphs plotted during a cable frequency response (attenuation) test: Near-end Crosstalk (NEXT), echo (return loss) response, and channel response. These tests are un-calibrated approximations of the cable's attenuation and should be used for reference only.

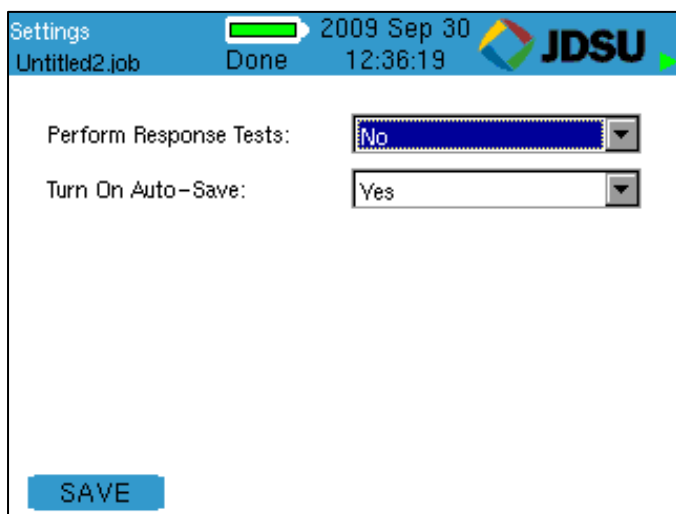

Figure 6.7: Other Settings

7 Properties Menu

The Properties menu displays buttons that contain information regarding: the state of charge associated with the battery, product revision levels, available free space on the internal memory, and JDSU support information.

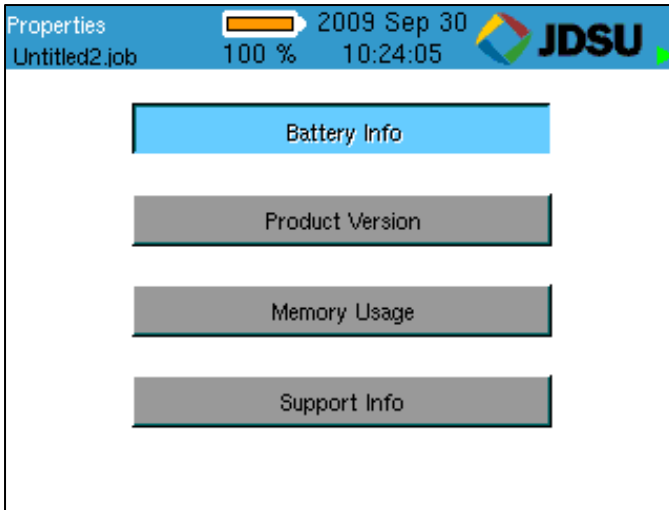

Figure 7.1: Properties Menu

Properties

7.1 Battery Info

This screen indicates whether the unit is operating on Battery Power or External Power (AC) and displays information that allows the user to monitor the remaining charge status and aging of the battery.

The Battery Info screen also includes a Reset Charge (RST CHR) F1 soft key. The purpose of this function is to reset the charge cycle when you change out the battery. You can also start a new charge cycle by disconnecting the AC adapter momentarily.

The battery from the remote can be placed into the main unit and its properties can be viewed.

NOTE: For additional power and battery information see the Battery and Power Management section of this guide.

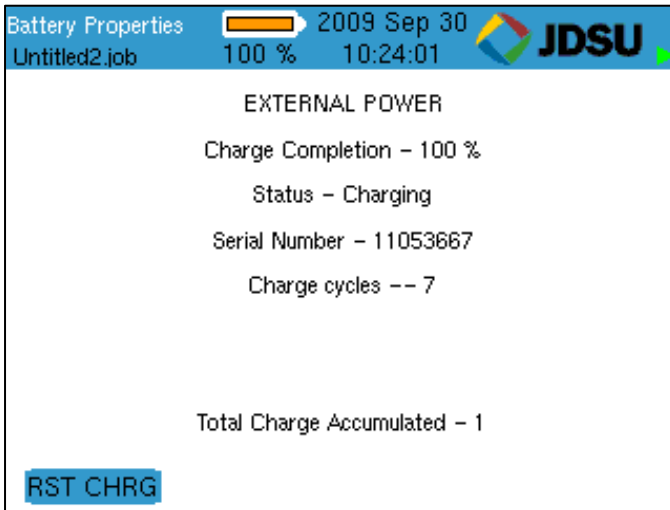

Figure 7.2: Battery Properties

7.2 Product Version

This screen displays the product's electronic serial number plus the revision levels of the hardware, firmware and software in the ValidatorPRO- NT.

NOTE: The actual serial number for warranty registration appears only on the rear decal for the unit and is not electronically stored in the unit.

Should you require technical assistance you may be asked to refer to this screen to confirm current product revision information. This screen will also be important in managing product upgrades and updates.

VAL_valapp shows the revision of TUI (firmware) installed.

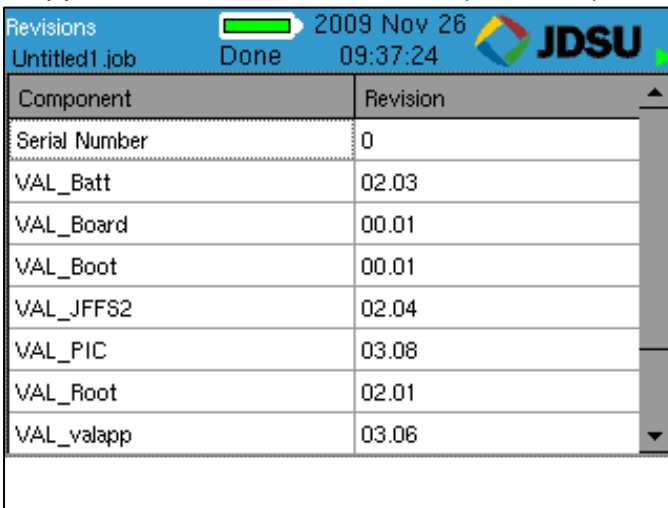

Component	Revision
Serial Number	0
VAL_Batt	02.03
VAL_Board	00.01
VAL_Boot	00.01
VAL_JFFS2	02.04
VAL_PIC	03.08
VAL_Root	02.01
VAL_valapp	03.06

Figure 7.3: Product Version

Properties

7.3 Memory Usage

The ValidatorPRO includes an internal memory and a USB thumb drive for transferring job files to and from the ValidatorPRO. The memory usage screen can be used to view the amount of available memory for either internal or external memory.

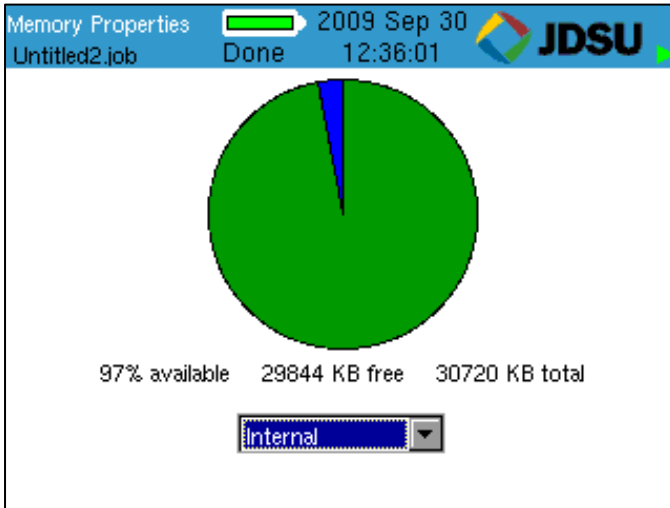

Figure 7.4: Memory Properties

7.4 Support Info

The Support Screen displays Technical Support contact information.

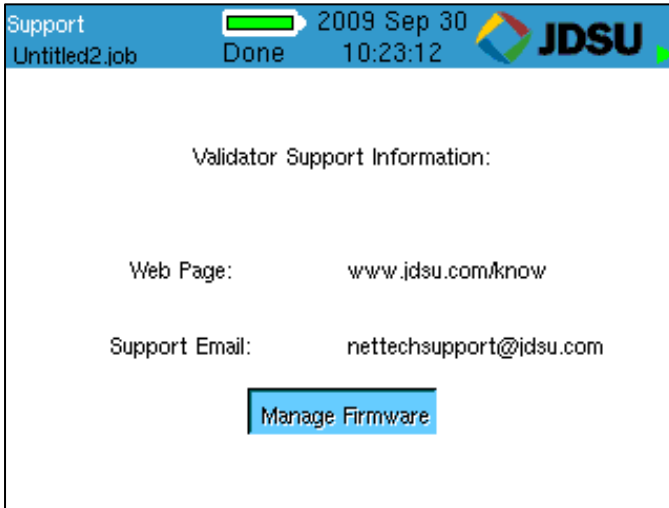

Figure 7.5: Support Info

8 File Management Menu

The File Management menu provides access to the Job Manager and the Copy/Move Utility.

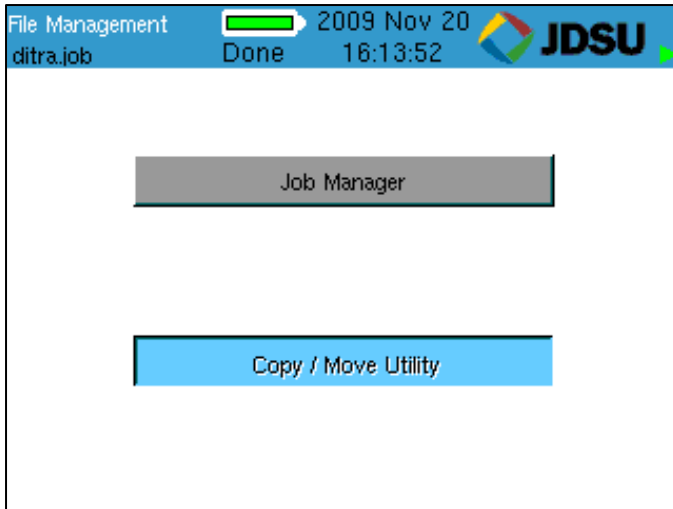

Figure 8.1: File Management Menu

8.1 Job Manager

The Job Manager displays a list of jobs that have been uploaded from Plan-Um or have been created in the ValidatorPRO and are on the internal or external memory. Highlight a job name and press the Open (F1) soft key to select an existing job to test or edit the job information using the Auto Test menu functions. Other function keys allow the job file to be copied, renamed, or deleted.

Job files can also be opened from the Auto Test | Job Utilities menu.

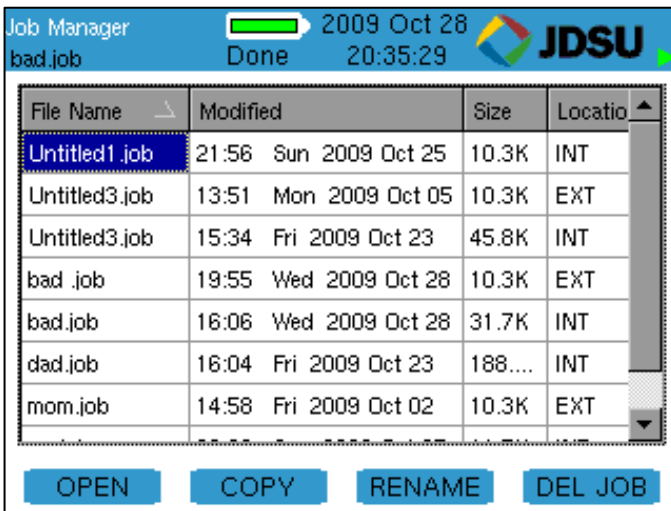

Figure 8.2: Job Manager

8.2 Copy/Move Utility

The Copy/Move Utility allows for files to be transferred to/from the internal memory to/from an external USB thumb drive. This utility is useful for transferring several job files to/from the internal memory or for copying template files to/from the internal memory. It is also useful for copying or moving screen shots, and power meter or Wireless (-NT only) CSV results files from the internal memory to an external USB thumb drive.

Use the left and right keys to move between the table and the memory location selection box. Once in the memory location selection box, select, the up and down arrows, and the ACCPT key are used to select which memory is shown in the table.

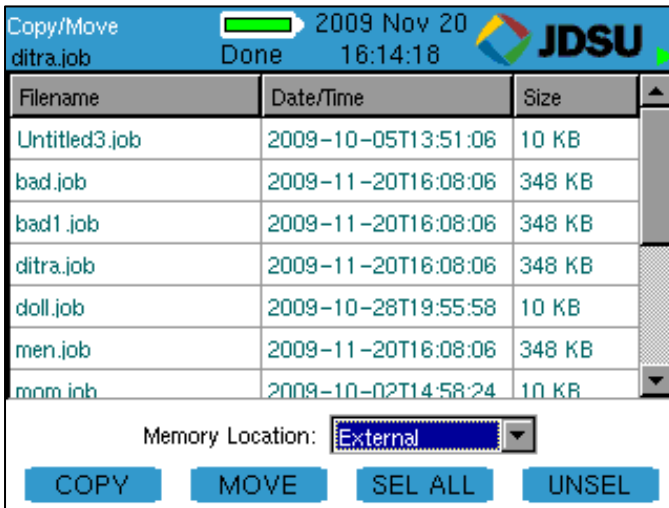

Figure 8.3: Copy/Move Utility

File Management

There are four function keys available:

- COPY (F1) - Copies selected files from selected memory location to other memory location.
- MOVE (F2) - Move selected files from selected memory location to other memory location.
- SEL ALL (F3) - Selects all files
- UNSEL (F4) - Deselects all selected files

You can individually select files by using the SEL button and Up and Down keys.

9 Auto Test Menu

Creating a job within Plan-Um and then running Auto Tests from the Cable Test Schedule on the ValidatorPRO is the easiest and most efficient way to test cables and document the results. See the Plan-Um section of this manual for detailed instructions on how to integrate job information and test results between Plan-Um and the ValidatorPRO.

Creating a job in Plan-Um and opening it on the ValidatorPRO is the simplest way to create a Cable Test Schedule and enter Site Information, Tester Information, and Custom Cable Definitions. If it is desired to create or edit this information on the ValidatorPRO, the Auto Test menu allows this.

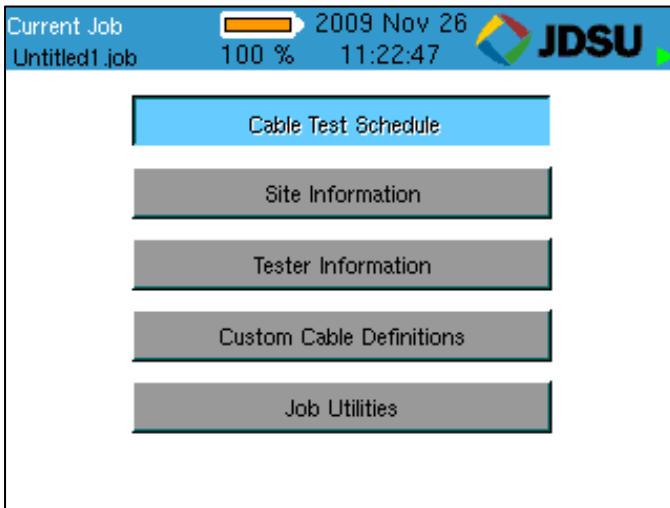

Figure 9.1: Auto Test Menu

The most common workflow is to open a job file from the USB thumb drive using Job Utilities then use the cable test schedule to run tests. All test results will be stored on the USB thumb drive. Once all tests are complete, the file can be saved, the USB thumb drive removed from the ValidatorPRO, connected to a PC, then the file opened with Plan-Um on a PC allowing reports to be printed.

Auto Test

Alternatively, the job file can be transferred from USB thumb drive to internal memory (eliminating the need to leave the USB thumb drive plugged in while running tests.)

9.1 Cable Test Schedule

The Cable Test Schedule displays all the individual cable runs associated with the open job. The open job is displayed at the top left corner of the display. For each cable, its ID, Type, the “from” and “to” are displayed along with the Test Result. If the cable has not been tested a question mark (?) will be displayed in the Result column.

ID	Type	From	To	Result
Cable001	CAT3	01 Net01	01 Panel01	✓ PASS
Cable002	CAT5	01 Net02	01 Panel01	Voip 100Mb
Cable003	CAT5E	01 Net03	01 Panel01	Voip 1000Ml
Cable004	RG-6	01 TV01	01 Panel01	✓ PASS
Cable005	CAT5E	01 Net04	01 Panel01	Voip 1000Ml
Cable006	CAT5E	01 Net05	01 Panel01	✗ FAIL
Cable007	CAT6	01 Net06	01 Panel01	Voip 1000Ml

Figure 9.2: Cable Test Schedule

To test a cable on the list, highlight the Cable ID you wish to test. Attach that cable to the appropriate connector on the main unit. Attach the remote unit to the other end of the cable you wish to test.

With the remote connected to the cable, the test function can be started by pressing the TEST button. You will hear relays switching in the main unit and remote. A link is established with the remote, and ValidatorPRO begins testing the cable to the parameters that have been defined for its type.

Once the tests are complete for a particular cable, the Cable Test Schedule displays the results and the test highlight automatically increments to the next cable in the list.

There are six functions available using the soft keys. The Function (F4) key is used to show the additional functions.

The six functions available are:

1. Add Cable (ADD CBL)
2. Delete Cable (DEL CBL)
3. Results
4. Page Up (PG UP)
5. Page Down (PG DOWN)
6. SORT

Add and delete cable allows cables to be added to or deleted from the cable test schedule. The ID, Type, From and To fields can be edited for new or existing cables using the alphanumeric keypad.

Results allows results of cable tests to be viewed on the ValidatorPRO. Please see the following section for more details on viewing test results.

Page up and page down can be used instead of the up and down arrows to allow for quicker scrolling through long cable test schedules.

Sort allows the cable test schedule to be sorted by any of the five columns. Select the column to be sorted using the arrow keys and press the SORT function key. The entire cable test schedule will then be sorted by that field. Pressing sort twice will reverse the sort order.

In addition to the functions available with the soft function keys, pressing the menu key will bring up window with several other choices:

- Cable Details
- Go to Top
- Go to Bottom
- First untested

Auto Test

9.1.1 Viewing Test Results

When a cable is selected and the Results soft function key is pressed, the test results will be displayed on the screen along with details of the test such as the date and time of the test. For Network (Ethernet) cables the results show include:

- Expected and measured wiremap
- Length
- Skew
- SNR
- BERT

The page up and page down soft function keys (F1 and F2) are used to change between summary/wiremap results and detailed results. The response (RESP) soft function key (F3) can be used to view the cable frequency response plot data.

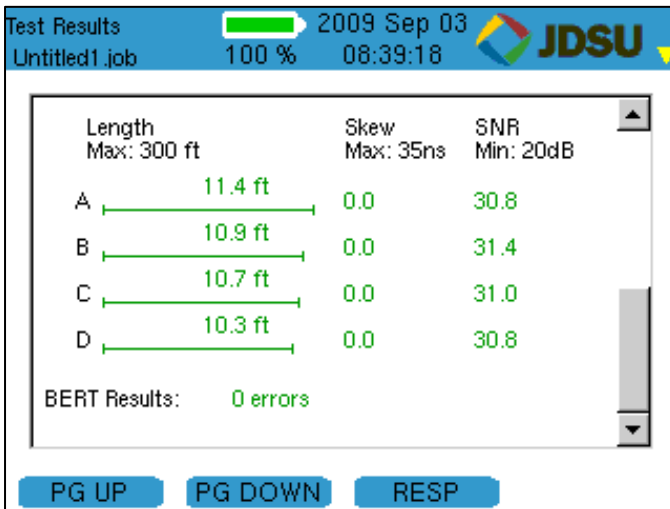

Figure 9.3: Test Results (Page 2)

9.2 Site Information

Selecting the Site Info button displays the Customer Contact Information associated with the currently open job. By highlighting and selecting a field you can update or change the information in each field, i.e.; Job ID, Contact name, etc. Press Accept to accept the changes that were made and exit that field. To save text press Menu, scroll to Save Job, and press Select.

The screenshot shows a handheld device interface for entering site information. The top status bar is blue and contains the text 'Site Info', 'Untitled1.job', 'Done', the date and time '2009 Nov 26 14:24:24', and the JDSU logo. Below the status bar is a white form with several text input fields. The fields are labeled as follows: 'Job ID: |', 'Company: _____', 'Contact: _____', 'Phone: _____', 'Email: _____', 'Address 1: _____', 'Address 2: _____', and 'City: _____'. At the bottom of the form are two blue buttons with white text: 'BACKSPC' and 'DELETE'.

Figure 9.4: Site Info

9.3 Tester Information

Selecting the Contractor Info button displays the Contractor Information associated with the currently-open job.

Information on this screen can be added or changed in the same manner as on the Site Info screen.

The screenshot shows a software interface for entering contractor information. The top bar is blue and contains the following elements from left to right: the text 'Job Info', a green progress bar, the date '2009 Nov 26', the JDSU logo (a colorful diamond shape), and the text 'Untitled1.job Done 14:24:32'. Below this bar is a white rectangular area containing several text input fields, each with a label to its left: 'Company:', 'Contact:', 'Phone:', 'Email:', 'Address 1:', 'Address 2:', 'City:', and 'State:'. A vertical scrollbar is on the right side of this input area. At the bottom of the screen, there are two blue buttons with white text: 'BACKSPC' and 'DELETE'.

Figure 9.5: Tester Information

9.4 Custom Cable Definitions

Selecting the Custom Cable Definitions button displays all defined cable types loaded into the ValidatorPRO from the current job and what auto tests will be performed for the cable type. The soft keys, F1 thru F3, allow for adding, editing, and deleting cable information.

The screenshot shows a software window titled "Data Test Parameters" with a blue header bar. The header bar contains a green progress bar, the text "2009 Oct 28", "20:34:15", and the "JDSU" logo. Below the header, the text "bad.job" and "Done" are visible. The main area of the window is a form with the following fields:

- Type Name: [text input]
- Length: [Yes/No dropdown menu]
- Speed: [None dropdown menu]
- pF/ft.: [text input]
- Skew: [text input]
- Mx Length(ft): [text input]
- SNR: [text input]
- Comment: [text input]

At the bottom of the window, there are three blue buttons labeled "BACKSPC", "DELETE", and "SAVE TYPE".

Figure 9.5: Custom Cable Definition (Data Cable)

9.5 Job Utilities

This screen has buttons to allow the creation of a new job file, open an existing job file, export a template file, save the file that is currently open, or save an open file as a file with a new name.



Figure 9.7: Job Utilities

9.5.1 New Job

The new job utility allows a new job file to be created on either the internal or external memory, specify a file name, and specify a TuT (template) file to be used for the new job.

9.5.2 Open Job

The open job utility provides access to the Job Manager where job files can be opened, copied, renamed, and deleted. The Job Manager is also accessible from the file management menu. More information on the Job Manger is provided in Section 8 (File Management Menu)

9.5.3 Export TuT

The export TuT utility creates a new template from open job file. The template name and memory location can be specified.

9.5.4 Save

The save utility saves the current job.

9.5.5 Save As

The Save As utility allows the open job to be saved with a different name. The memory location can also be specified.

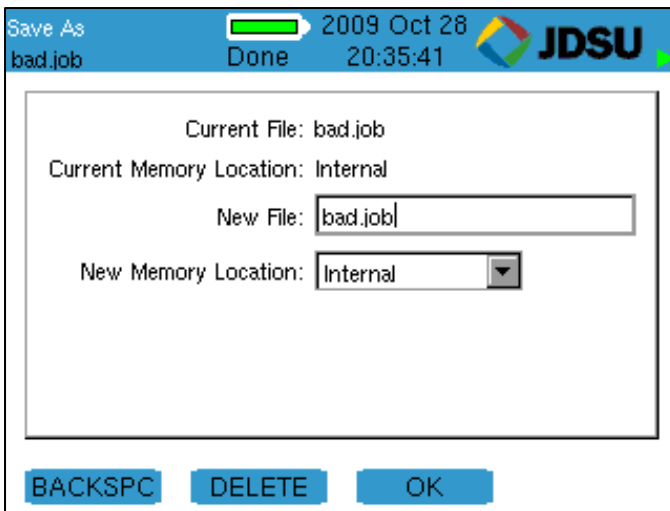

Figure 9.8: Save As

10 Manual Test Menu

The Manual Tests menu gives access to individual tests that can be performed on Data, Phone, 2-wire, or fiber cables. The tests that can be performed for each selected cable type are listed on the Manual Test screen for that type. Manual test results for copper cables cannot be saved. For fiber cables, manual test results can be saved as .CSV files and imported into common spreadsheet programs.

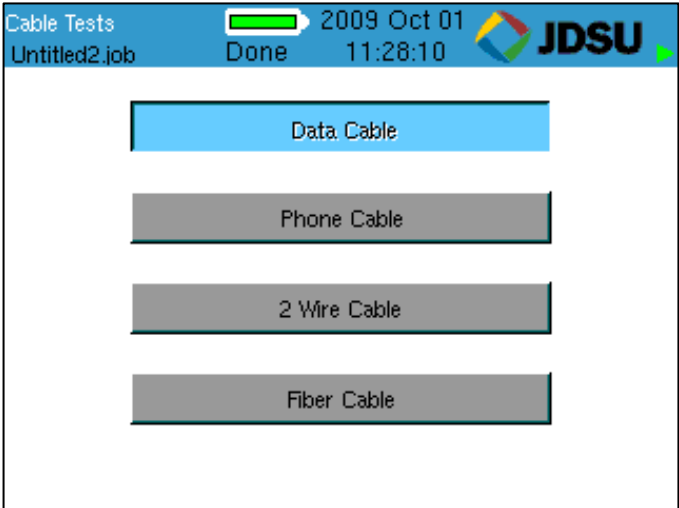

Figure 10.1: Manual Cable Test Menu

Manual Tests

10.1 Data Cables

Data Cables are defined as cables wired to T568A/B pin numbering and pairing. Cable tests check cables for correct wiremap, length, Skew and Signal to Noise Ratio. Bit Error Rate Tests (BERT) can be performed to ensure the cable can carry 1000BASE-T Gigabit Ethernet signals. It is also possible to send tone over the cable and trace cables to active devices with hub flash.

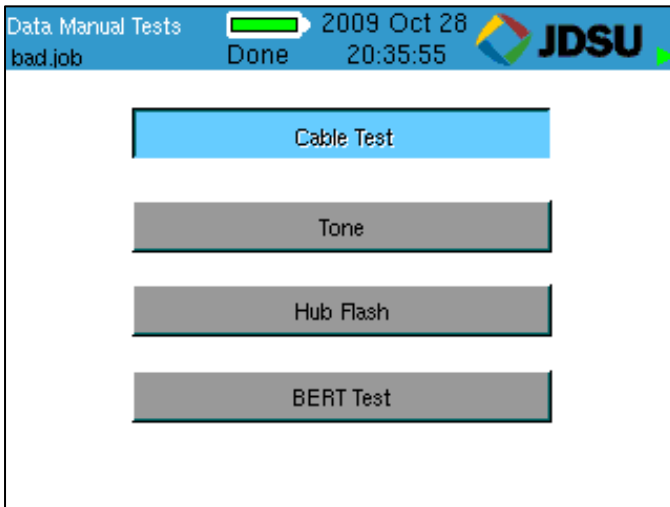

Figure 10.2: Manual Data Cable Test Menu

10.1.1 Cable Test

Cable Tests can be performed with the ValidatorPRO remote, the set of 1-8 wiremapping remotes (RJ11/RJ45) (TP612), the TP312 RJ45 ID-only remotes, or with no remote. The TP612 remote wiremappers are designed to report wiremap length and Skew results only. A Link Test Error message appears “Unable to Measure SNR”. To measure Signal to Noise Ratio you must use the ValidatorPRO remote unit. Testing without a remote only allows for length to be measured. The soft function keys available vary based on the type of remote being used.

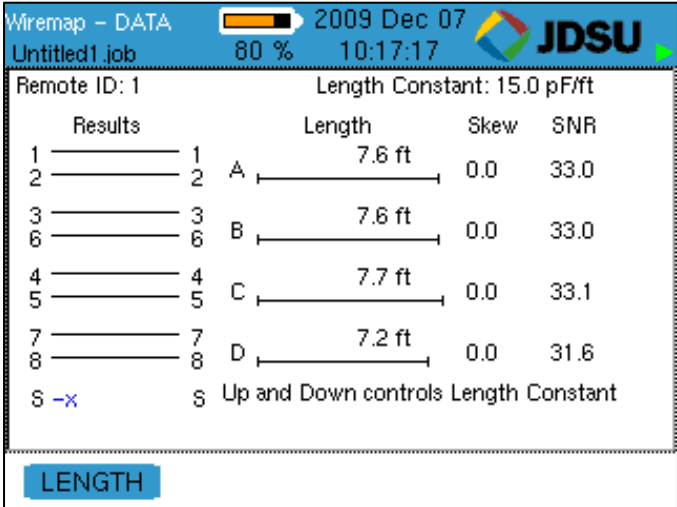

Figure 10.3: Manual Data Cable Test Results

Length Constant is used for length measurement and is adjusted in .1pF increments by pressing the up and down arrow keys. The displayed cable length is recalculated as the length constant is changed. This allows an unknown length constant to be determined by attaching a known length of cable and running the test. The length constant can be varied up or down until the displayed length matches the measured length. The displayed length constant is then the correct value for that cable. This same adjustment feature is on both the Phone and 2-Wire test screens.

Manual Tests

10.2 Phone Cables

Phone Cables are defined as cables wired to the USOC 3-pair standard for pin numbering and pairing. The test shows opens, shorts and length of the run. The wiremap and length measurements are displayed.

10.3 Two-Wire Cables

2-wire cables are tested for wire map and length. Tone can also be sent over the cable.

10.4 Fiber Cables

Optical power on Single-Mode and Multi-Mode fiber cables can be measured for absolute power (dBm) as well as relative power (dB) at 850, 1300, 1310, 1490 and 1550 nm. Activate the optical power meter by selecting Manual tests from the Start menu and then select Fiber Cables

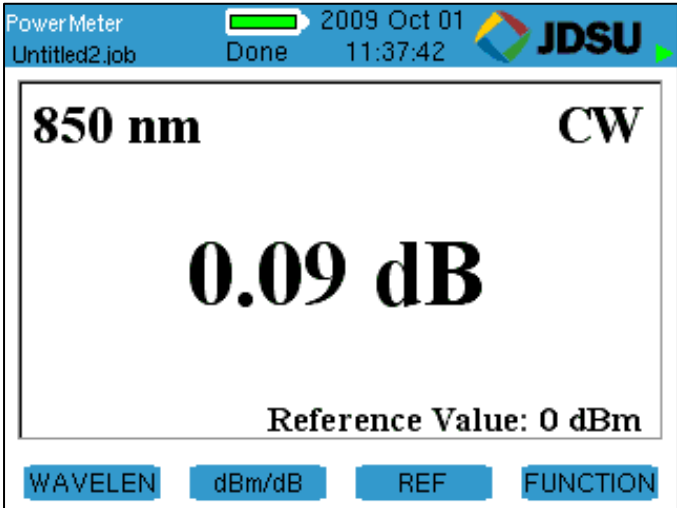

Figure 10.4: Optical Power Meter

From the power meter screen use the soft keys to control the actions of the power meter. There are six functions available with the F4 soft key used to change the functions available for selection. The six functions available are:

1. WAVELEN (Wavelength)
2. dBm/dB
3. REF (Reference)
4. AUTO
5. SAVE
6. NEW

Continually pressing WAVELEN cycles through the five wavelengths. The selected wavelength is shown in the top left of the screen.

Manual Tests

dBm/dB changes the measurement mode from absolute to relative.

REF makes the current power measurement the reference value and sets the dB measurement to 0 dB. If REF is pressed while in absolute (dBm) mode, the power meter will change to relative (dB) measurement mode and zero the meter. The current reference level in dBm is always shown in the bottom right portion of the screen.

The AUTO function places the power meter in auto wavelength detection mode allowing it to work with JDSU optical sources such as the OLS-6. If the optical source being measured is modulated, the frequency of modulation will be shown in the top right of the screen.

Power meter results can be saved to a .csv file on either the internal or external memory. Each time the SAVE soft key is pressed a new entry in the .csv file will be created.

If it is desired to create a new file (instead of appending the existing file), the NEW softkey can be used.

11 Network Test Menu (ValidatorPRO-NT)

Active Network Tests are only available on the ValidatorPRO-NT (NT1155). There are six active network tests designed to provide insight into the functionality of wired and wireless Ethernet/IP networks. The five tests are:

1. Power over Ethernet
2. Port Discovery
3. Ping
4. Layer 2 Discovery Protocols
5. Hub Flash
6. WiFi

To run network tests, select Network Tests from the Start Menu then select the appropriate network test with the arrow keys and press SELECT.

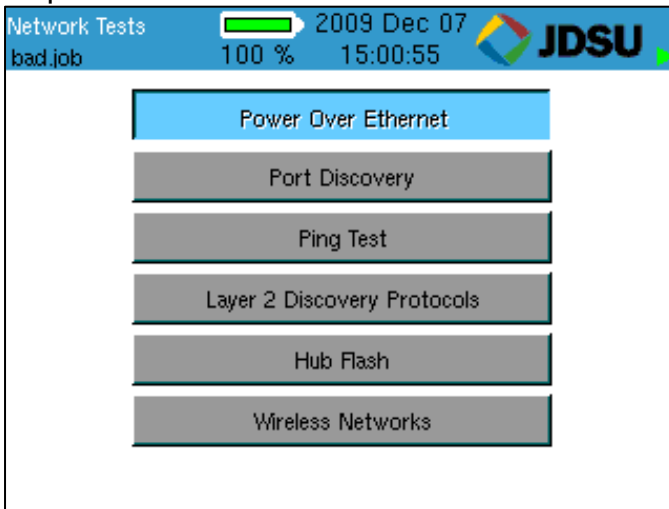

Figure 11.1: Network Tests Main Screen

11.1 Power over Ethernet (PoE)

The Power over Ethernet test detects and reports voltage presence on the line. If no voltage is present initially, the Validator PRO proceeds to initiate IEEE802.3af PoE protocol to activate, test, and report whether PoE is found at the far end (the Power Source), the type and mode of PoE, polarity and wiring (e.g. 1-2 pair positive and 3-6 pair negative), and whether it meets the IEEE802.3af PoE standard (pass or fail). Both the PoE voltage and current will be reported after the test.

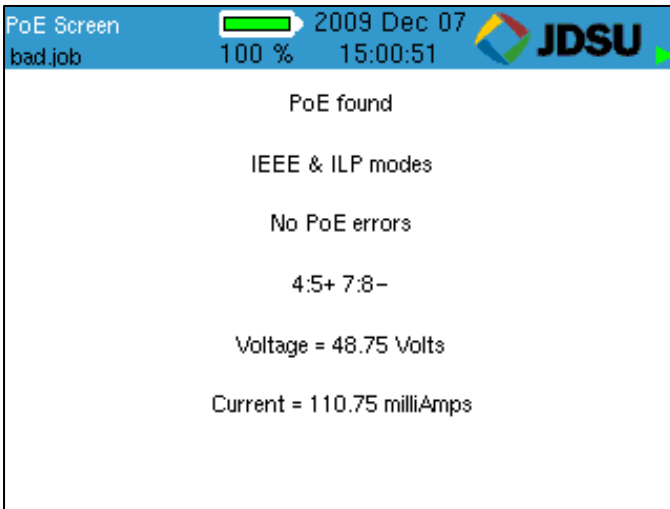

Figure 11.2: Power over Ethernet

11.2 Port Discovery

Port discovery identifies telephone or network devices connected to the other end of the jack or cable. The test begins with a search for voltages that may be present. If voltages are found, the patterns for commonly used services are compared to the voltages observed and reported as phone, ISDN or legacy phantom power as appropriate. If the voltage pattern is unknown, the port pin conditions are reported.

If no telephone or voltage sources are found, ValidatorPRO attempts an Ethernet link. If a link is found, information about the link is displayed:

- Identifies the Ethernet connection
- Speed linked at (10, 100 or 1000 Megabit)
- Type of link (MDI, MDI-X or Auto MDI/MDI-X)
- Advertised Speeds of the connected Ethernet device
- Advertised duplex capabilities of connected Ethernet device
- SNR
- Skew if 1000BASE-T

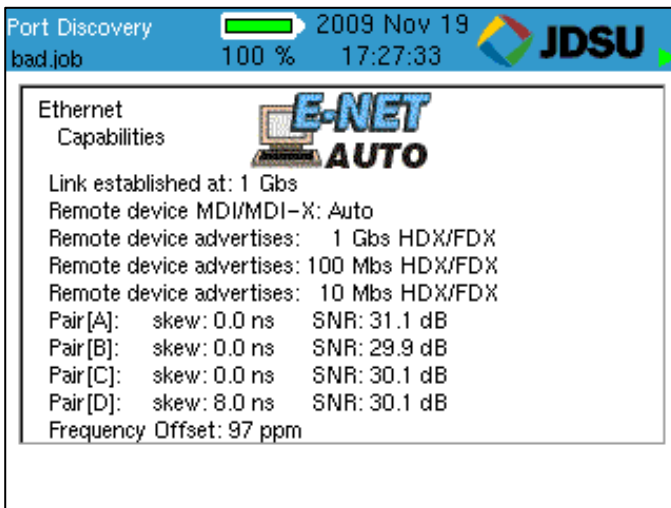

Figure 11.3: Ethernet Port Discovery

Network Tests

If neither voltages nor Ethernet is detected, ValidatorPRO searches for its remote to run a cable test. If the remote is found, a manual mode cable test is run and the remote ID, wiremap, full Signal to Noise Ratio, and Skew test results (1000Mbit only) are displayed. Speed testing, as well as placing tone on a cable, is performed in the Manual Test mode of the ValidatorPRO only. If a remote is not found, a one-ended test for shorts and split pairs is run and the results are reported.

If the results appear to be un-powered Ethernet equipment, that is reported as well.

To run Port Discovery tests, select Port Discovery from the Network Tests menu and connect the ValidatorPRO main unit's Network jack to the interface to be tested.

11.3 Ping

The Ping Test is used to verify connectivity to resources on or off the network and IP addresses. The Ping Test will simultaneously Ping up to seven different IP addresses and can be run in DHCP or manual addressing modes.

To run Ping tests, select Ping from the Network Tests menu and connect the ValidatorPRO main unit's Network jack to the interface to be tested.

In DHCP mode, the ValidatorPRO-NT's assigned address and the addresses of the router/gateway and DNS server plus the net mask are obtained automatically from a DHCP server and the values displayed on the ValidatorPRO. Press select button on Get IP Parameters to start the DHCP request process.

The Ping Tool soft key (F3) only shows on the IP address screen once valid DHCP information or manual IP addresses are configured.

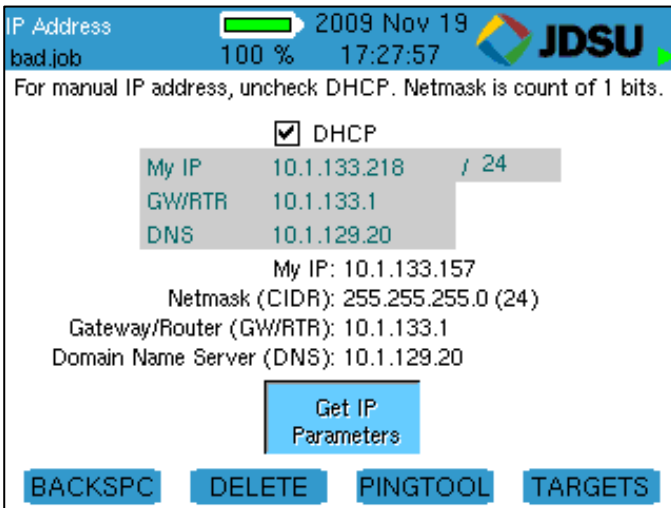

Figure 11.4 Ping Tool – IP Address

For manual IP addresses, uncheck the DHCP mode box by pressing the up and down arrow keys to highlight the DHCP box and press Select to deselect DHCP mode. Use the arrow keys to highlight the My IP, Gateway Router (GWRTR)

Network Tests

and Domain Name Server. Edit these fields as necessary using the keypad, Backspace (F1) and Delete (F2) soft keys. Press Accept to confirm your current selection and move to the next field. The Netmask is entered next to My IP as a count of ones starting from the left (255.255.0.0 = 16, 255.255.255.0 = 24, etc.). Press the down arrow to Select the box titled Configure IP Parameters and initiate the operation to verify that the MY IP address entered is not in use already.

The Ping Targets must be set manually. To change the IP targets, press the Targets soft key (F4) and edit these fields as necessary using the keypad, Backspace (F1) and Delete (F2) soft keys. The www.com soft key (F3) is used as a shortcut to add the common “www.” prefix and the “.com” suffix to an entered name. Pressing the F3 soft key would change “JDSU” to “www.jdsu.com”. When entering addresses, the * button is a shortcut for the period (.) punctuation mark needed to enter dotted-quad or URL addresses. Press Quit to return to the previous screen (either IP Address or Ping Tool).

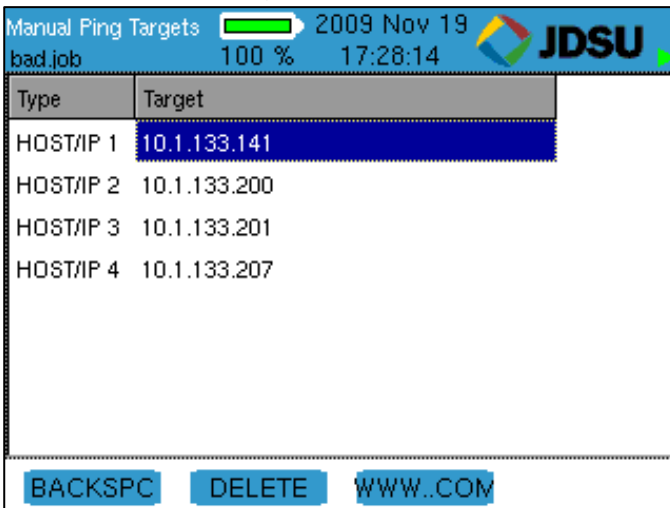

Type	Target
HOST/IP 1	10.1.133.141
HOST/IP 2	10.1.133.200
HOST/IP 3	10.1.133.201
HOST/IP 4	10.1.133.207

Figure 11.5: Manual Ping Targets

Network Tests

All the IP addresses that are currently setup to be pinged are displayed on entry. Uncheck the box next to any addresses you do not want to ping. The Host/IP address can be edited directly on this screen (the default URL is www.google.com) and the Targets soft key (F4) and subsequent screen is used to edit the four other user defined targets. Press the Ping soft key to start the ping operation of up to seven IP addresses simultaneously. Press Quit to stop the Ping test. The ValidatorPRO will issue a DHCP release request to the DHCP server when in DHCP mode.

You can increase the length of the data packet used to ping by highlighting the target IP Address and using the right arrow key to highlight the word Long. Press Select to toggle the size of the data packet between normal and long.

Pressing the PING softkey activates the test.

Network Tests

11.4 Layer 2 Discovery Protocols

This feature detects Layer 2 Discovery Protocol messages broadcast by Layer 2 devices over the network to inform each other of their existence and capabilities. The ValidatorPRO-NT supports Cisco Discovery Protocol (CDP) and Link Layer Discovery Protocol (LLDP)

To view Layer 2 (L2) Discovery Protocol broadcast messages select Network Tests from the Start menu then select L2 Discovery Protocols from the Network Tests menu. Next connect a patch cable from the ValidatorPRO-NT main unit's network port to the Ethernet interface to be monitored for L2 discovery protocols.

L2 discovery protocol information automatically displays and a message "Reading L2 Discovery Packets from Network" appears on the screen.

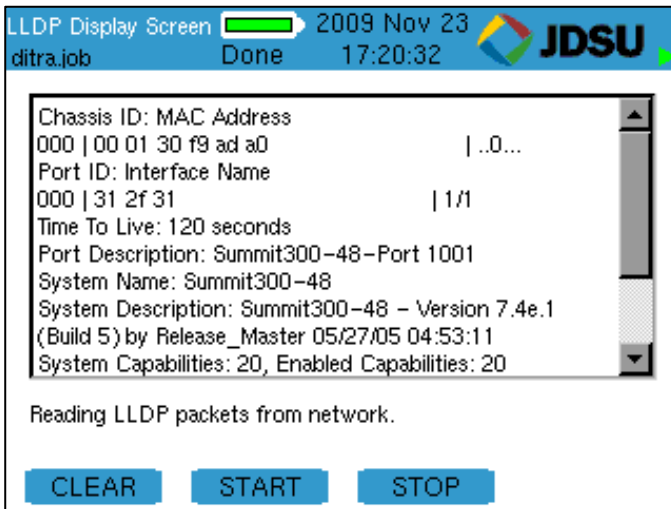

Figure 11.6: LLDP Display Screen

The soft function keys allow the test results to be cleared and the reading of L2 packets to be stopped and started.

11.5 Hub Flash

Hub flash sends an intermittent link signal to flash the link status light on Ethernet equipment. A specific data rate or “Any” can be selected to have the hub and the ValidatorPRO auto negotiate the speed. Pressing the F1 soft key starts this test. Hub flash is also on the ValidatorPRO from the Manual Test menu.

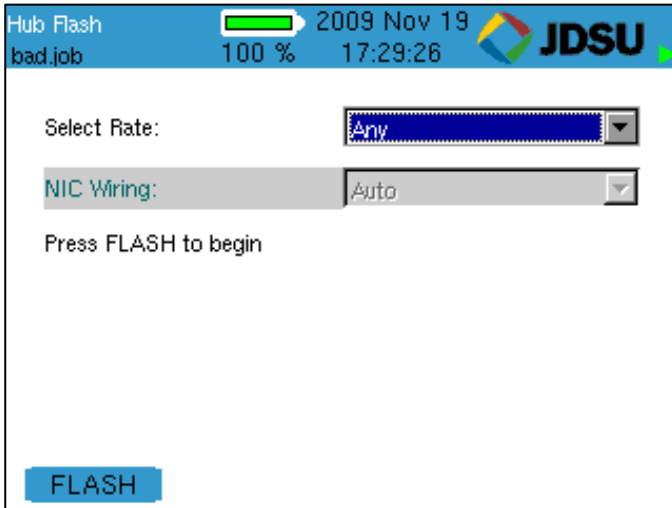

Figure 11.7: Hub Flash.

11.6 Wireless Networks

Selecting Wireless Networks from the Network Tests menu will power on the internal 802.11 b/g/n device and begin searching for Managed and Ad-Hoc networks. Networks found will be displayed with the following information:

- Level
- Mode
- Security (On or off)
- Protocol
- Channel
- SSID/MAC

Network Tests

Mode will display if the network is a managed (infrastructure) or ad-hoc network. Protocol will display the type of WiFi network found. SSID will be shown unless the wireless network is set to hide its SSID.

If a wireless network was found but has since been lost, the level will display LOST.

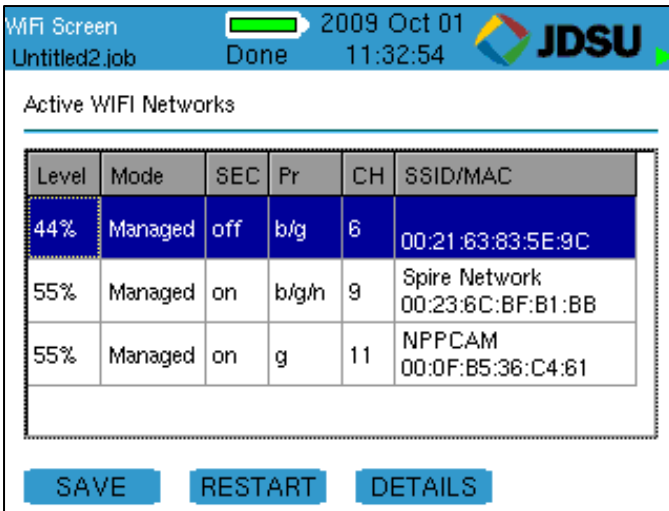

The screenshot shows a mobile device interface titled "WiFi Screen". At the top, there is a status bar with "Untitled2.job", "Done", the date "2009 Oct 01", the time "11:32:54", and the "JDSU" logo. Below the status bar, the text "Active WIFI Networks" is displayed. A table lists three active networks. The first network has a signal level of 44%, is a Managed network, has security off, protocol b/g, channel 6, and SSID/MAC 00:21:63:83:5E:9C. The second network has a signal level of 55%, is a Managed network, has security on, protocol b/g/n, channel 9, and SSID/MAC Spire Network 00:23:6C:BF:B1:8B. The third network has a signal level of 55%, is a Managed network, has security on, protocol g, channel 11, and SSID/MAC NPPCAM 00:0F:B5:36:C4:61. At the bottom of the screen, there are three buttons: "SAVE", "RESTART", and "DETAILS".

Level	Mode	SEC	Pr	CH	SSID/MAC
44%	Managed	off	b/g	6	00:21:63:83:5E:9C
55%	Managed	on	b/g/n	9	Spire Network 00:23:6C:BF:B1:8B
55%	Managed	on	g	11	NPPCAM 00:0F:B5:36:C4:61

Figure 11.8: WiFi Results

The Save soft key saves the discovered information to the internal memory as a .csv file that can be read by most spreadsheet programs. The copy/move utility can be used to transfer the file from internal to external USB memory. The Menu key provides a shortcut to the copy/move utility.

The Restart soft key clears all results and begins a new scan.

The Details soft key displays additional details about the selected network such as noise level and encryption type.

Select networks by using the up and down arrows on the keypad.

12 WEEE Directive Compliance



JDSU has established processes in compliance with the Waste Electrical and Electronic Equipment (WEEE) Directive, 2002/96/EC, and the Battery Directive, 2006/66/EC.

This product, and the batteries used to power the product, should not be disposed of as unsorted municipal waste and should be collected separately and disposed of according to your national regulations. In the European Union, all equipment and batteries purchased from JDSU after 2005-08-13 can be returned for disposal at the end of its useful life. JDSU will ensure that all waste equipment and batteries returned are reused, recycled, or disposed of in an environmentally friendly manner, and in compliance with all applicable national and international waste legislation. It is the responsibility of the equipment owner to return equipment and batteries to JDSU for appropriate disposal. If the equipment or battery was imported by a reseller whose name or logo is marked on the equipment or battery, then the owner should return the equipment or battery directly to the reseller. Instructions for returning waste equipment and batteries to JDSU can be found in the Environmental section of JDSU's web site at www.jdsu.com. If you have questions concerning disposal of your equipment or batteries, contact JDSU's WEEE Program Management team at WEEE.EMEA@jdsu.com.

13 Customer Services and Warranty

This section provides a description of customer services available through JDSU (including returns policies and procedures) and warranty information.

13.1 Customer Service (Standard Services)

Customer Service accompanies the sale of every JDSU product. Customer Service services include:

- Technical Assistance (Business Hour)
- Instrument Repair (Under Warranty Repair, Calibration Services, and Upgrade Services)
- Immediate Return Authorizations

13.2 Technical Assistance

Expert business hour technical support is included with your product. Please reach the technical support organization in your region:

North America:

866-228-3762 x 2300

Europe, the Middle East & Africa:

49-7121-86-1345

E-mail: nettechsupport@jdsu.com

13.3 Repair, Calibration and Upgrades

Our service centers provide repair, calibration, and upgrade services for JDSU equipment. JDSU understands the impact of equipment down time on operations and is staffed to ensure a quick turnaround. Available services include the following:

13.3.1 Repair

All equipment returned for service is tested to the same rigorous standards as newly manufactured equipment. This

Customer Services and Warranty

ensures products meet all published specifications, including any applicable product updates.

13.3.2 Calibration

JDSU's calibration methods are ISO approved and based on national standards. JDSU recommended factory calibration interval of this product is (24) months. The stated confirmation interval shall be regarded as a recommendation. The real definition of the confirmation interval should be made by the user. The type of application and the environmental conditions should be taken into account. Contact a JDSU service center or customer service in your region regarding calibration.

13.3.3 Factory Upgrades

Any unit returned for a hardware feature enhancement will also receive applicable product updates and will be thoroughly tested, ensuring peak performance of the complete feature set.

13.3.4 Equipment Return Instructions

Please contact your regional Technical Assistance Center to get a Return or Reference Authorization to accompany your equipment.

For each piece of equipment returned for repair, attach a tag that includes the following information:

- Owner's name, address, and telephone number.
- The serial number (if applicable), product type, and model.
- Warranty status. (If you are unsure of the warranty status of your instrument, contact Technical Assistance.)
- A detailed description of the problem or service requested.
- The name and telephone number of the person to contact regarding questions about the repair.

Customer Services and Warranty

- The return authorization (RA) number (US customers), or reference number (European Customers).

If possible, return the equipment using the original shipping container and material. If the original container is not available, the unit should be carefully packed so that it will not be damaged in transit; when needed, appropriate packing materials can be obtained by contacting JDSU Technical Assistance. JDSU is not liable for any damage that may occur during shipping. The customer should clearly mark the JDSU-issued RA or reference number on the outside of the package and ship it prepaid and insured to JDSU.

13.4 Warranty Information

JDSU guarantees that its products will be free of all defects in material and workmanship. This warranty extends for the period of 12 months for test instruments and 3 months for cables from date of manufacture or purchase (proof of purchase required).

All products deemed defective under this warranty will be repaired or replaced at JDSU's discretion. No further warranties either implied or expressed will apply, nor will responsibility for operation of this device be assumed by JDSU.

The provision of hardware, services and/or software are subject to JDSU's standard terms and conditions available at www.jdsu.com/terms.

13.4.1 Warranty registration

Please register your product at www.jdsu.com/know-register

www.jdsu.com/know

Document Information
Doc.# 21146576
Revision 000
English

