

# Resi-Tester™ Whole-House Cable Tester

---

## User's Guide

[www.jdsu.com/know](http://www.jdsu.com/know)





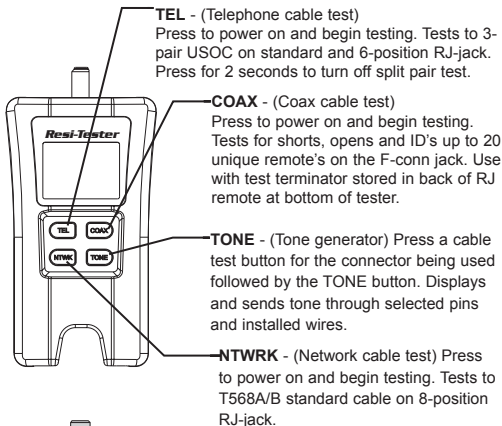

**COAX  
TERMINATOR**

**REMOTE UNIT** - Squeeze remote at finger grip openings in main unit to remove. Use same connector on remote as on main unit.

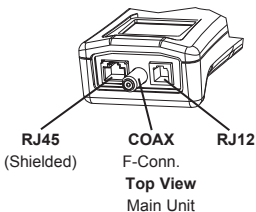
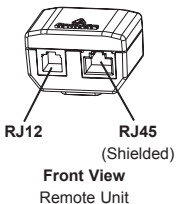

## **WARNING!**

*Do not attach to AC power. The Resi-Tester™ may be damaged and cause a safety hazard for the user.*

## **CAUTION!**

*Improperly crimped, damaged or un-crimped plugs can damage the jacks on the Resi-Tester™. Inspect plugs for proper termination and crimping before inserting into the tester. Contacts should always be recessed into the plastic grooves of the plug. Do not use 6-position plugs with the 8-position (network) jack.*

## Features

- Tests network (8-wire), telephone (6-wire) and coax cabling systems
- Supports 8 network remotes and 20 coax remotes (optional, see accessory list)
- Large seven-segment LCD with icons for clear results
- Cable test results displayed in wire map format
- Tests for shorts, opens, miswires, reversals and split pairs
- Displays PASS icon for correctly wired T568A/B, both one-to-one & uplink (cross-over) cables
- Displays PASS icon for correctly wired 6-pin telephone cables both straight-through & reversed
- Tone generator mode for use with tone tracers
- Auto-off in any mode and low power consumption for long battery life
- Modular Plug Remote and Coax Test Terminator store in the bottom end of the case

## Description

The Resi-Tester™ is designed to test all common low voltage cabling systems found in today's automated businesses and homes; telephone, network or video. The Resi-Tester™ has a large, bright LCD display and four momentary buttons used to directly access each function. The remote attaches to the main unit for storage and patch cable testing.

The Resi-Tester™ is turned on by pressing any one of the four momentary function buttons and begins operating in the mode for the button pressed: telephone (TEL), coax (COAX), network (NTWK) or tone generator (TONE). The corresponding connectors at the top end of the tester are labeled the same as their mode switches. An LCD icon for the currently selected mode will be on or flashing on the screen. To turn the Resi-Tester™ off when in one of the cable test modes, press the button for a different cable test mode, but not the TONE button. Pressing the TONE button will start the tone generator in the Tel Tone, the Coax Tone or Ntwk Tone mode, depending on the current cable test mode. The tone mode will be discussed in detail later on in this section.

Upon completion of a telephone or network cable test, the wire map, ID and any faults are displayed. The top line of numbers on the display represents the connector pins on the main unit. The second line of pin numbers represents the connector pin numbers of the remote, normally being the same as the top line for a one-to-one wired cable. If there is a miswire, the pin numbers on the second line will indicate the pin numbers detected and the “Fail” icon will be on. The icon and the pins involved in the error will flash. If no connection was detected for some of the pins, the first and second line of pin numbers will be blank in those pin locations. If a short is detected, the second line will have a ‘-’ in those positions along with the “Short” icon being on. If a split pair is detected, those pin positions on the first and second line will be flashing the pin numbers detected from the remote and the “Split” icon will be flashing. If there are multiple errors to display, there will be a combination of the above error displays. The ID icon will have a number directly to the right of it, indicating the remote ID number detected from the remote. A new test is in progress whenever the “Tel” or “Ntwk” icons are on.

In the coax mode, the “Open”, “Short” or “Pass” icon will be on to indicate the results of a test. If the cable passes, the “ID” icon will be on as well as a remote ID number, on the bottom line of the display. The “Coax” icon turns on when a test is in progress.

As mentioned above, the tone generator operates in Telephone, Coax and Network modes. The different modes are provided so that the pins or pairs being driven with a tone signal are displayed in terms of one of the three connectors. The specific mode is selected by pressing one of the cable test buttons (TEL, COAX or NTKWK) followed by the TONE button. If the Resi-Tester™ was off when the TONE button is pressed, the last cable test mode used will be selected. The tone generator saves the driven pins for each mode independently. For example, selecting a different pin to drive in network mode will not change the driven pin in coax mode. Pressing any cable test mode button will turn off the Resi-Tester™ when in tone mode.

**Telephone (TEL) Cable Test Mode** - The Resi-Tester™ assumes the 6-position jack on the main unit and the remote will be used for connecting the tester to the cable run to be tested. This mode uses the 3-pair USOC

standard to define the pairs. Connector pins 1-6, 2-5 and 3-4 are the pairs defined by this standard. The tester will display the “Pass” icon when all 6 pins are correctly wired in a one-to-one order. If all 6 pins are correctly wired in the reverse order, the “Pass” icon along with a flashing “Rev” icon will be displayed. Standard telephone cables used between a phone set and a wall jack are usually reverse-pinned.

After turning on the telephone cable test mode, subsequent presses of the TEL button of less than 2 seconds long, forces a new test cycle to begin immediately upon release of the button. This is useful to immediately begin a new test when attaching a new cable to Resi-Tester™. Holding the TEL button down for more than 2 seconds, turns the split pair test off. The “Split” icon and the word “OFF” appearing on the screen briefly indicate this. Another long press will toggle back to the split pair testing, and so on. When split pair testing is not required, as in the testing of flat satin cable, the split pairs can be turned off, so a cable may pass based on continuity only.

**Network (NTWK) Cable Test Mode** - The Resi-Tester™ assumes the 8-position jack on the main unit and the remote will be used for connecting the tester to the cable run to be tested. The TIA/EIA 568A/B standard is used to define the pairs. Connector pins 1-2, 3-6, 4-5 and 7-8 are the pairs defined by this standard. The A and B standards are the same except for color-coding and are indistinguishable from each other by electrical testing. The tester will display the “Pass” icon when all 8 pins are correctly wired in a one-to-one order. If all 8 pins are correctly wired with the 1-2 and 3-6 pairs crossed, the “Pass” icon will be displayed along with a flashing “Uplink” icon. Uplink cables are also known as crossover or T568A-to-T568B cables and are commonly used to connect two computers or two hub/switches directly together.

After turning on the network cable test mode, subsequent presses of the NTWK button of less than 2 seconds, forces a new test cycle to begin immediately upon release of the button. This is useful to immediately begin a new test when attaching a new cable to the Resi-Tester™. Holding the NTWK button down for more than 2 seconds, turns the split pair test off. The

“Split” icon and the word “OFF” appearing on the screen briefly indicates this. Another long press will toggle back to the split pair testing, and so on. When split pair testing is not required, as in the testing of flat satin cable, the split pairs can be turned off, so a cable may pass based on continuity only.

**Tone** - The tone mode generates audio tones for use with tone tracers on all pairs, a selected pair or a selected pin. The signal generated on a pair has the signal on one pin and the complement of the signal on the other pin of the pair, yielding a nominal 10 volts peak-to-peak across the pair. The pin number of the pin or the letters “P”( for pin) and “S” (for shield) being driven with tone and the currently selected tone pattern are displayed on the screen along with the “Tone” icon and the icon for the connector assumed to be used. Once in the tone generator mode, the TONE button steps to the next connector pin(s) drive option for presses of less than 2 seconds. When the TONE button is pressed and held down for longer than 2 seconds, the tone pattern options are stepped through in turn until the button is released. The tone pattern options are Hi, Lo, HiLo1 and HiLo2. The HiLo options are dual or warble tones of differing

pattern duration. Pressing any button other than TONE turns off the Resi-Tester™. The tone will turn off automatically after about 2.4 hours.

**Volts!** - The Resi-Tester™ monitors for voltage present on the jacks during each test cycle. If voltage is found, the “Volts!” icon is displayed and testing stops until the voltage is removed.

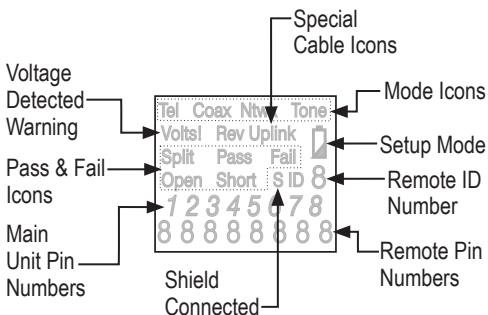

Resi-Tester™ LCD Display

# Instructions for Use

Resi-Tester™ powers off automatically 9 minutes after the last button press in cable testing modes and after 2.4 hours in tone mode. Be sure to install a battery if using for the first time, see battery installation section.

## Cable Testing

**To Test a Patch Cable** (see caution about cables with bad plugs above)

- 1) Plug one end of patch cable into main unit.
- 2) Plug other end of cable into remote unit.
- 3) Press TEL or NTWK as appropriate for the jack the patch cable is connected to. The Resi-Tester™ will turn on and begin a test. If tester was already on, press TEL or NTWK to initiate a new test. Results are invalid if a cable is attached during a test in progress.
- 4) To turn Resi-Tester™ off, press COAX button.

## **To Test Coax**

- 1) Attach one end of cable to be tested to F-connector on main unit.
- 2) Remove remote unit from main unit by squeezing the remote lightly between the thumb and forefinger through the openings provided in the main unit and pull out of storage pocket. Remove coax remote from storage pocket on backside of remote and attach to the other end of the cable to be tested.
- 3) Press the COAX button to turn on the unit and begin testing. The results are updated about once a second.
- 4) To turn Resi-Tester™ off, press TEL or NTKW buttons.
- 5) For un-terminated cable, use LB32; "F" push-on plug to alligator clip adapters.

## ***To Place Tone on a Cable***

- 1) Connect cable to be traced to a main unit jack. For best signal, do not connect a remote to the other end. Due to the shielding effect of twisted pairs, the strongest signal is obtained by having one wire of a pair carry tone. Selecting a single pin instead of a pair will do this. For coax, the Tone is best applied to the shield and the shield cannot be grounded.
- 2) Turn on Resi-Tester™ by pressing the button associated with the connector to be used followed by pressing the TONE button. Short presses of the TONE button will select a different pin. Holding down the TONE button for more than 2 seconds will select a different tone pattern.
- 3) To turn Resi-Tester™ off, press any button except TONE. The tone will turn off automatically after about 2.4 hours.

## Interpreting Cable Test Results

The Pass icon will be on if the cable has all pins properly connected per T568A/B for network cables or per 3-pair USOC for telephone cables. The Fail, Short, Open or Split icon will be on if there is a wiring error. The wire map will display the end-to-end connections measured whenever possible.

The Pass icon will also be on with a flashing Uplink icon if a network cable has the 1-2 and the 3-6 pairs transposed to indicate a properly wired uplink (crossover) cable. In Telephone mode, the Rev icon will flash if all connected pins are in reverse order and the Pass icon will also be on if all 6 connections are present. Telephone modular plug cables used between the wall jack and a phone set are usually reverse pinned.

**Definition of Errors** - (See failure example drawings) The three classes of faults discussed below are in order of severity. The severity has to do with the ability of a more severe error to mask less severe errors. For example, if there is a short in the cable, miswires and split pairs may not be detected for the pairs involved in the short fault.

**Short** - The pair has a low resistance connection from one wire of the pair to the other wire of the pair or to any other wire in the cable or the shield. A short is indicated by the Short icon being on and flashing hyphenes ( - ) in the appropriate pin positions on the second line for the pin numbers involved in the shorts plus a flashing S icon if the shield is shorted to a pin.

**Miswire** - A wire or both wires of a pair are not connected to the correct pins at the other end of the cable. The wire map shows the pin numbers from line 1 (main) to line 2 (remote). A reverse pair is a special case of a miswire in which the pair is wired to the correct pair of pins or to another designated pair of pins, but the two leads are reversed. The Resi-Tester™ is able to test for split pair errors as long as the wiring errors are in pairs. The Fail icon and the pin numbers, which are miswired, will be flashing.

**Split Pair** - A split pair is an error in the twisting of the wires together within the cable. The cables generally are made up of eight wires twisted together in 4 pairs. These 4 pairs are designated as pairs by the wiring standards and are intended to carry a signal and its return. 1&2, 3&6, 4&5 and

7&8 are the pairs designated by T568A/B for a RJ45 jack or plug. A cable can be wired with correct continuity but not with correct pairing. This most often happens when the cable is terminated consistently at both ends, but in the wrong order. A dynamic or AC test is required to detect this type of error. If the only error is a split pair error, the cable has correct continuity. If cross talk is not a concern, as in flat satin cable, the cable is good if the only error is the split pair error. The Split icon and the pin numbers on the first and second line of the wire map with split pairs flash when there is a split pair error.

Resi-Tester™ has the ability to turn off the split pair error testing. Pressing the button for the current cable test mode for more than 2 seconds turns off the split pair testing. The “Split” icon and the word “OFF” appears on the screen briefly to indicate this. The split pair testing will resume the next time the tester is turned on, or may be toggled back on by another 2 second press of the current test mode button.

DARK = ON  
LIGHT = FLASHING

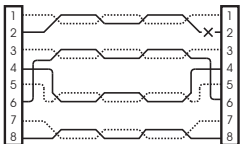

OPEN

Ntwk							
Open							S ID 2
1	2	3	4	5	6	7	8
		3	4	5	6	7	8

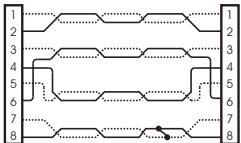

SHORT

Ntwk							
						Short	S ID 2
1	2	3	4	5	6	7	8
1	2	3	4	5	6	-	-

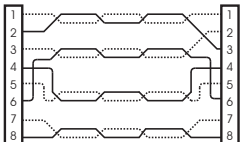

MISWIRE

Ntwk							
						Fall	S ID 2
1	2	3	4	5	6	7	8
1	3	2	4	5	6	7	8

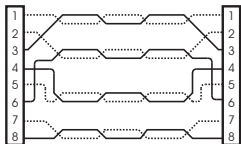

SPLIT PAIR

Ntwk							
						Split	S ID 2
1	2	3	4	5	6	7	8
1	2	3	4	5	6	7	8

(1 not twisted with 2; 3 not twisted with 6)

T568A/B Passing Cable (unshielded)

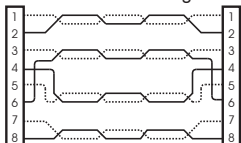

Ntwk							
						Pass	ID 2
1	2	3	4	5	6	7	8
1	2	3	4	5	6	7	8

## Battery Replacement

When the battery low icon is on, the battery should be replaced as soon as practical.

The cable testing results will become unreliable when the battery reaches about 4.5 volts. To replace battery:

- 1) Remove the screw from the battery door on the back of the unit with a #1 Philips-head screwdriver.
- 2) Pull battery out of cavity and remove battery snap.
- 3) Connect a new Alkaline 9 volt battery to battery snaps. Place battery back into body with battery snaps placed toward front end of compartment.
- 4) Replace battery door and screw being careful to not over tighten the screw.

## Specifications

### Physical Dimensions:

Size: 13.2 x 7.3 x 4.1 cm  
(5.2 x 2.9 x 1.6 inches)

Weight: 242 grams (8.5 oz.) with battery and remote

### Environmental:

Operating temperature: 0 to 50 °C  
(32 to 122 °F)

Storage temperature: -10 to 60 °C  
(14 to 140 °F)

Humidity: 10% to 90%, non-condensing

**Battery Life** (9V Alkaline battery, typical) times are for the full capacity of the battery used continuously in one of the following modes -

Standby: 2.5 years  
Cable Testing: 150 hours  
Tone Generator: 250 hours

**Cable Types:** Shielded or unshielded, CAT-6, CAT-5E, CAT-5, CAT-4, CAT-3 and Coax

**Minimum cable length for testing of split pairs:** 1 meter (3 feet)

**Coax Cable:** 100 ohms maximum DC resistance, center conductor plus shield

## Accessories

**LB32** - 24", F push-on plug to alligator clip set (to use with TP315)

**TP20** - 7.5" cable assembly with no-fault 6 position plugs, reverse-pinned. Use to map and test 2, 4 or 6 pin telephone wiring. Can be used with RJ45 (8-position) jacks and will not damage pins or connector.

**TP40** - 12" Cable assembly, RJ45 to alligator clips

**TP62** - Adapter, F-conn plug to BNC jack. Use to convert main unit F-conn jack to BNC jack

**TP63** - Adapter, F-conn jack to BNC jack. Use to convert Coax test terminators to BNC jack.

**TP310** - Set of 10 numbered F-conn test terminators

**TP311** - Set of 20 coax remote identifiers for Resi-Tester™ and Testifier™

**TP312** - Set of 20 RJ45 wiremappers for Resi-Tester™ and Testifier™

**TP314** - Set of 20 RJ11 wiremappers for Resi-Tester™ and Testifier™

**TP315** - Set of 20 Speaker Seeker™ alligator clip remote identifiers for Resi-Tester™ and Testifier™

**TP608** - Set of 7 numbered remotes for LanScaper™, LanRoverPRO™, Resi-Tester™ or Testifier™

**KP410** - Security & Alarm System adapter kit includes (9) RJ45 to alligator clip lead sets and an LB66 in a zippered pouch. Use with TP608 to map and test individual twisted pair runs.

# Customer Services

This section provides a description of customer services available through JDSU (including returns policies and procedures) and warranty information.

## **Customer Service (Standard Services)**

Customer Service accompanies the sale of every JDSU product. Customer Service services include:

- Technical Assistance (Business Hour)
- Instrument Repair (Under Warranty Repair, Calibration Services, and Upgrade Services)
- Immediate Return Authorizations

***Technical Assistance*** Expert business hour technical support is included with your product.

***Instrument Repair*** Our service centers provide repair, calibration, and upgrade services for JDSU equipment. JDSU understands the impact of equipment down time on operations and is staffed to ensure a quick turnaround. Available services include the following:

*Product Repair* — All equipment returned for service is tested to the same rigorous standards as newly

manufactured equipment. This ensures products meet all published specifications, including any applicable product updates.

*Calibration* — JDSU's calibration methods are ISO approved and based on national standards.

*Factory Upgrades* — Any unit returned for a hardware feature enhancement will also receive applicable product updates and will be thoroughly tested, ensuring peak performance of the complete feature set.

***Equipment Return Instructions*** Please contact your regional Technical Assistance Center to get a Return or Reference Authorization to accompany your equipment. For each piece of equipment returned for repair, attach a tag that includes the following information:

- Owner's name, address, and telephone number.
- The serial number (if applicable), product type, and model.
- Warranty status. (If you are unsure of the warranty status of your instrument, contact Technical Assistance.)
- A detailed description of the

problem or service requested.

- The name and telephone number of the person to contact regarding questions about the repair.
- The return authorization (RA) number (US customers), or reference number (European Customers).

If possible, return the equipment using the original shipping container and material. If the original container is not available, the unit should be carefully packed so that it will not be damaged in transit; when needed, appropriate packing materials can be obtained by contacting JDSU Technical Assistance. JDSU is not liable for any damage that may occur during shipping. The customer should clearly mark the JDSU-issued RA or reference number on the outside of the package and ship it prepaid and insured to JDSU.

## Warranty Information

JDSU guarantees that its products will be free of all defects in material and workmanship. This warranty extends for the period of 12 months for test instruments and 3 months for cables from date of manufacture or purchase (proof of purchase required).

All product deemed defective under this warranty will be repaired or replaced at JDSU's discretion. No further warranties either implied or expressed will apply, nor will responsibility for operation of this device be assumed by JDSU.



### **WEEE Directive Compliance**

JDSU has established processes in compliance with the Waste Electrical and Electronic Equipment (WEEE) Directive, 2002/96/EC. This product should not be disposed of as unsorted municipal waste and should be collected separately and disposed of according to your national regulations. In the European Union, all equipment purchased from JDSU after 005-08-13 can be returned for disposal at the end of its useful life. JDSU will ensure that all waste equipment returned

is reused, recycled, or disposed of in an environmentally friendly manner, and in compliance with all applicable national and international waste legislation. It is the responsibility of the equipment owner to return the equipment to JDSU for appropriate disposal. If the equipment was imported by a reseller whose name or logo is marked on the equipment, then the owner should return the equipment directly to the reseller. Instructions for returning waste equipment to JDSU can be found in the Environmental section of JDSU's web site at [www.jdsu.com](http://www.jdsu.com). If you have questions concerning disposal of your equipment, contact JDSU's WEEE Program Management team at [WEEE.EMEA@jdsu.com](mailto:WEEE.EMEA@jdsu.com).

Notes:

Notes:



---

[www.jdsu.com/know](http://www.jdsu.com/know)

*Document Information*

*Doc. # TU9856*

*Revision 500, 05-08*

*English*

